

TUBULAR GAGES AND VALVES

5/8" O.D. Glass Standard, 3/4" O.D. Glass Optional

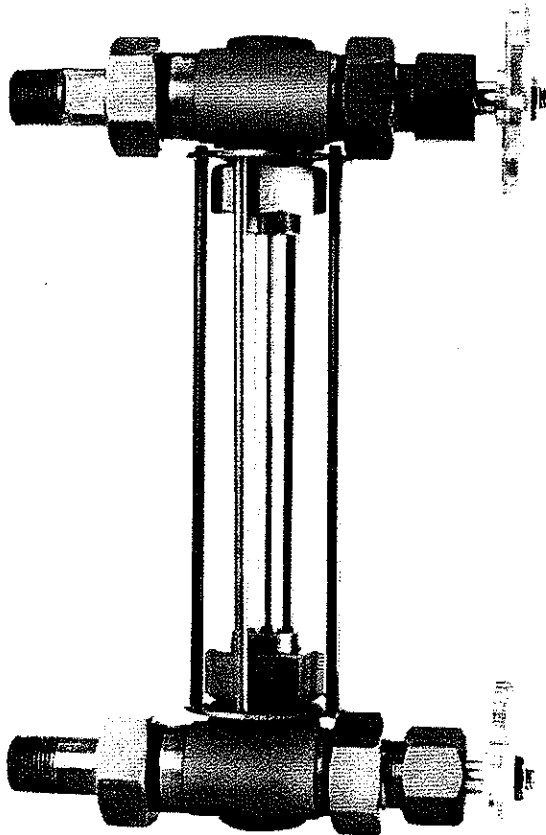

Shown with Type 2T valves

Glass-Trac Tubular Glass Gages are available in any length desired and can be fitted with Type 1T or 2T Gage Valves (see Page 18). These gages provide 360° visibility of the liquid level through strong, clear glass. Tubular glass is used in three types: Red Line, High Pressure and Heavy Wall. Pressure ratings are different for each type and also depend upon glass length (see next page). If glass breakage occurs, a stainless steel ball check shuts off each valve. Glass tubes should be cut 1 1/2" shorter than valve center-to-center. The resulting visible glass length is 5" less than the valve center-to-center.

Red Line glass provides a bright crimson stripe against a narrow white strip throughout the length of the tube. Liquid levels are easy to see against this special optical effect. The glass is heat-resistant and ends are fire polished. Red Line is available in both 5/8" and 3/4" O.D.

High Pressure glass is a versatile, medium-strong type of tube used in many applications. It is crystal clear and ends are fire polished.

Heavy Wall glass has the highest pressure rating of all tubular glass. It is extremely clear, corrosion resistant, will not scratch easily and is extra resistant to heat shock. Ends are ground.

Four carbon steel guard rods and two guard rod rings are used to protect tubular glass gages. The rods are anchored in each ring which is fastened to the valve behind the union nut. Rods should be cut 1/4" shorter than valve center-to-center. A transparent plastic sheath also is available to clamp around the glass tube. Sheath length should be 4 3/8" shorter than valve center-to-center. Also available is an expanded metal gage glass protector for additional protection of the glass. Specify gage valve center-to-center for proper sizing of this assembly.

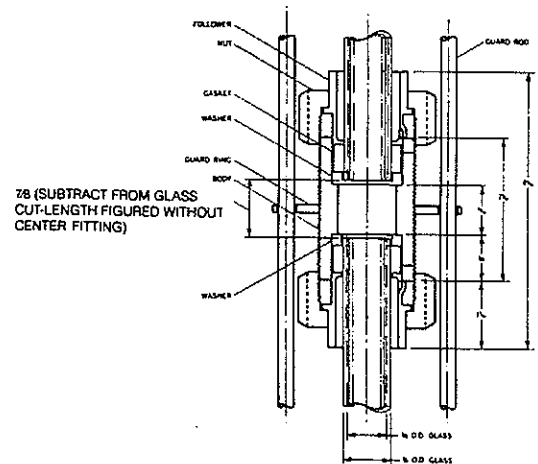
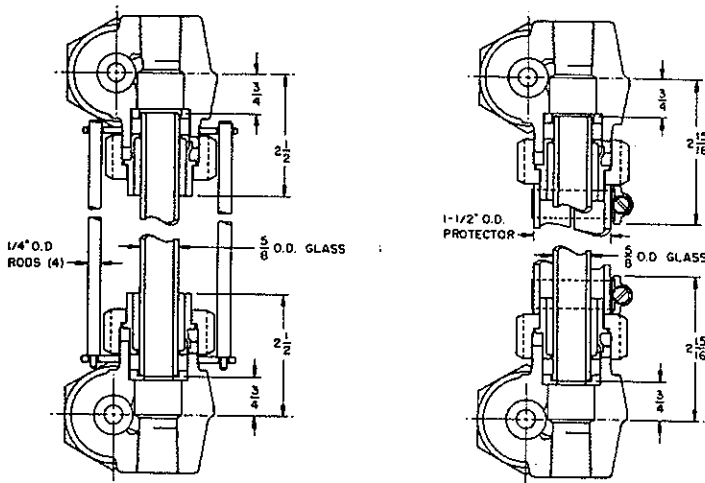

CENTER FITTING
(Recommended when valve centers exceed maximum recommended service length)

NOTE: Type 1T 4000 psi Tubular Valve and Type 2T 4000 psi Tubular Valve shown on page 15.

MAXIMUM RECOMMENDED WORKING PRESSURE, PSIG

GLASS LENGTH	5/8" O.D. RED LINE		3/4" O.D. RED LINE		5/8" O.D. HIGH PRESSURE	
	TO 150° F*	TO 425° F**	TO 150° F*	TO 425° F**	TO 150° F*	TO 425° F**
8"	370	285	360	280	435	320
10"	345	280	340	275	420	315
12"	335	280	330	275	410	305
14"	325	275	320	270	390	295
15"	320	275	315	270	380	290
16"	315	270	310	265	375	285
18"	305	265	300	260	360	280
20"	290	265	285	260	350	270
22"	280	260	275	255	335	265
24"	265	255	260	250	320	255
30"	235	†	230	†	280	†
36"	205	†	200	†	245	†
48"	165	†	160	†	195	†
60"	125	†	125	†	150	†
72"	90	†	90	†	100	†

GLASS LENGTH	3/4" O.D. HIGH PRESSURE		5/8" O.D. HEAVY WALL		3/4" O.D. HEAVY WALL	
	TO 150° F*	TO 425° F**	TO 150° F*	TO 425° F**	TO 150° F*	TO 425° F**
8"	425	315	600	350	600	350
10"	410	310	600	345	600	345
12"	400	300	600	340	600	340
14"	385	290	600	335	600	335
15"	375	285	600	330	600	330
16"	370	280	600	325	600	325
18"	355	275	600	320	600	320
20"	345	265	600	315	600	315
22"	330	260	590	310	590	310
24"	315	250	580	300	580	300
30"	275	†	550	†	550	†
36"	240	†	500	†	500	†
48"	190	†	340	†	340	†
60"	145	†	†	†	†	†
72"	100	†	†	†	†	†

*To 150°F and/or CORROSIVE SERVICES **For 150-425° and/or CORROSIVE SERVICES
 †Maximum recommended length in this service is 24".
 ‡Maximum recommended length in this service is 48".

TUBULAR VALVES (Brass)

1/2" NPT Male Tank Connection
5/8" O.D. Tubular Glass Gage Connection

For low pressure water vessels, storage tanks, containers, etc., Glass-Trac provides Type OT Brass Valves for Tubular Gages. The valves are made up with 5/8" O.D. Pyrex Red Line, High Pressure or Heavy Wall Glass from stock. Each valve contains a brass ball check which closes the valve in the event of glass breakage. Two guard rods are used. The lower valve also is fitted with a threaded drain cock. Type OT Brass Valves are suitable for working pressures up to 200 psig at or under 400°F.

Tubular glasses are available in any length and should be cut 1 1/2" shorter than valve center-to-center. Guard rods should be 3/4" longer than the valve center-to-centers.

Visible length is 3" less than the valve centers.

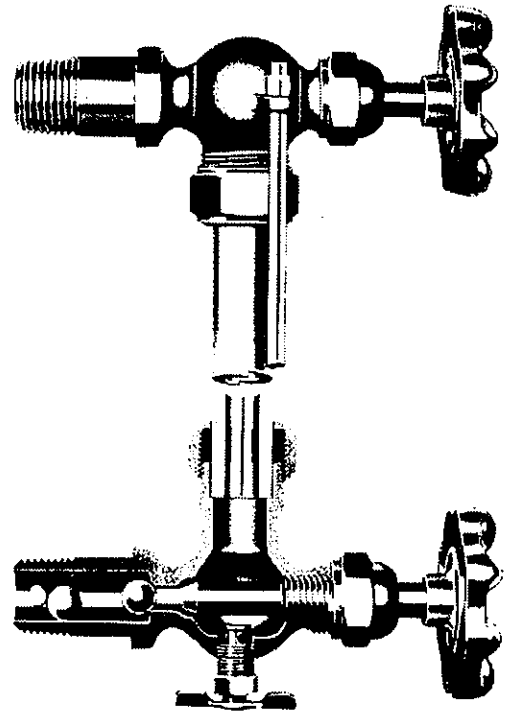

TUBULAR VALVES

Type 1T & 2T

4000 psig CWP 6000 psig Test
 3/4" NPT Male Union Tank Connection
 5/8" O.D. Tubular Glass Gage Connection
 1/2" NPT Female Drain Connection

Glass-Trac Offset Tubular Gage Valves are identical to Type 1 and 2 S and U Valves except they are fitted with the 5/8" O.D. tubular glass connection. The Type 2T Valve also can be furnished in the coarse thread design and with quick-operating lever for remote operation by chain. Both valves have a molded Teflon packing ring and rubber glass gaskets as standard for services up to 250° F. For temperatures to 425° F, valves have wire-graphite packing and Viton® glass gaskets. In the event of tubular glass breakage, a stainless steel ball check closes the valve to prevent further loss of fluid.

PRESSURE - TEMPERATURE RATING			
Teflon Packing		Wire-Graphite Packing	
4000 psi	100 F	3470 psi	300 F
3730 psi	200 F	3200 psi	* 400 F
3600 psi	250 F	3150 psi	425 F

NOTES: These ratings are for the valves only and not the tubular glass gages. See glass gage ratings on page 14.

PARTS

ITEM NO	NAME	STANDARD	316 SS WETTED PARTS
		MATERIAL	MATERIAL
1	BODY	CARBON STEEL	316 SS
2	UNION NUT	CARBON STEEL	CARBON STEEL
3	PACKING NUT	CARBON STEEL	CARBON STEEL
4	PACKING FOLLOWER	316 SS	316 SS
5	PACKING RING	TEFLON	TEFLON
6	PACKING WASHER	17-4 PH SS	17-4 PH SS
7	STEM	416 SS ①	316 SS
8	STEM NUT	CARBON STEEL	CARBON STEEL
9	NAME PLATE	4165	304 SS
10	HAND WHEEL	ALLOY ZINC	ALLOY ZINC
11	BALL	440 SS	440 SS
12	BALL RETAINER	316 SS	316 SS

ITEM NO	NAME	STANDARD	316 SS WETTED PARTS
		MATERIAL	MATERIAL ②
*13	MALE CONNECTOR	CARBON STEEL	316 SS
14	BONNET ②	416 SS	316 SS
15	SEAT ②	416 SS	316 SS
16	GLASS FOLLOWER	CARBON STEEL	CARBON STEEL
17	GLASS GASKET	RUBBER	RUBBER
**18 OR 19	LOWER GLASS SUPPORT	CARBON STEEL	316 SS

* ITEM NO.13 HAS HOLE WITH 1/16 ECCENTRICITY FOR ± 1/8 MAXIMUM MISALIGNMENT ON THE OVERALL CENTER-TO-CENTER.

** ITEM NO.21 IS USED IN LOWER VALVE ; ITEM NO.20 IN UPPER VALVE.

NOTE: Valve shown is for bottom left hand (or top right hand) location. Opposite hand is reversed. Valves are furnished in pairs of one bottom left hand and one top left hand.

① For Type 1 - 416 SS

② Available in Type 2 Valve only.

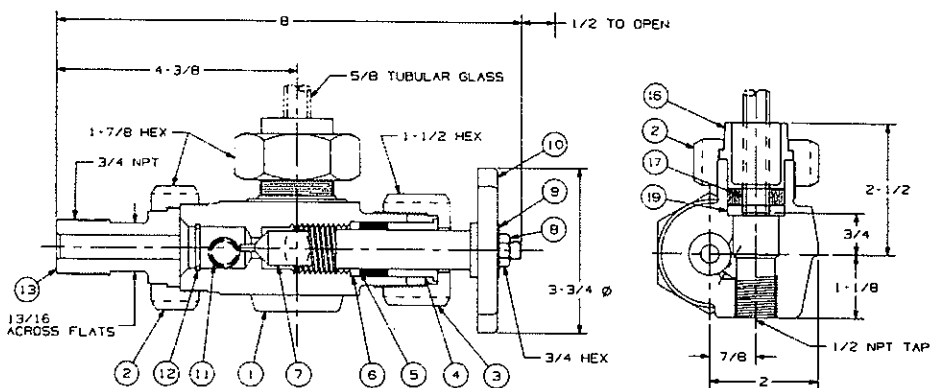

TYPE 1T

Weight per set approximately 10 lbs. 12ozs.

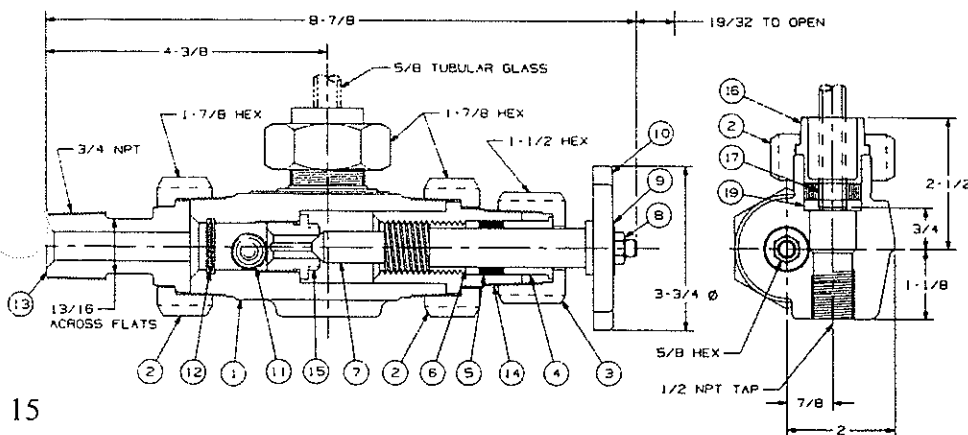

TYPE 2T

Weight per set approximately 11 lbs. 12ozs.

Optional Tank Connections shown on pages 26 and 27. Optional Gage Connections shown on page 25.

