

ITEM NO.	NAME	CARBON STEEL	STAINLESS STEEL WETTED
1	WELDING PAD	C1018 CDSR	316L SS
2	COVER	CARBON STEEL	CARBON STEEL
3	GLASS	TEMPERED	TEMPERED
7	SHIELD	AS REQUIRED	AS REQUIRED
4	GASKET	NON-ASBESTOS	NON-ASBESTOS
5	CUSHION	NON-ASBESTOS	NON-ASBESTOS
6	BOLT	ASTM A193 B7	ASTM A193 B7

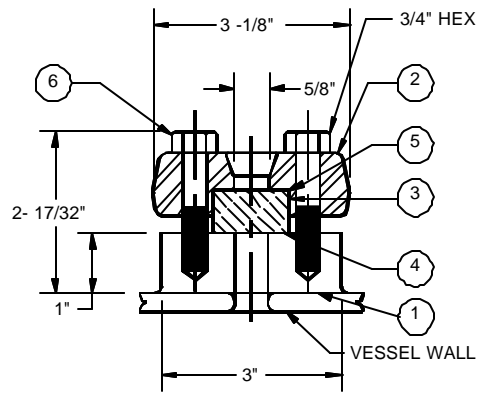

SECTION REFLEX "X-X"

SIZE NO.	NUMBER OF SECTIONS					NUMBER OF SECTIONS					DIM "C" IN INCHES
	DIMENSION "A" IN INCHES					DIMENSION "B" IN INCHES					
	1	2	3	4	5	1	2	3	4	5	
1	5 1/4					3 3/4					3 3/4
2	6 1/4					4 3/4					4 3/4
3	7 1/4	14 1/2				5 3/4	13				5 3/4
4	8 1/4	16 1/2				6 3/4	15				6 3/4
5	9 3/8	18 3/4				7 7/8	17 1/4				7 7/8
6	10 5/8	21 1/4	31 7/8			9 1/8	19 3/4	30 3/8			9 1/8
7	11 3/4	23 1/2	35 1/4	47	58 3/4	10 1/4	22	33 3/4	45 1/2	57 1/4	10 1/4
8	13 3/8	26 3/4	40 1/8	53 1/2	66 7/8	11 7/8	25 1/4	38 5/8	52	65 3/8	11 7/8
9	14 1/8	28 1/4	42 3/8	56 1/2	70 5/8	12 5/8	26 3/4	40 7/8	55	69 1/8	12 5/8

Customer _____
 Cust. P. O. #: _____
 Factory #: _____
 Rep P.O. #: _____
 Assembled _____ "Centers"
 Tag #'s: _____

**WELD PAD
 SERIES WP
 REFLEX**

120-08



P.O. Box 2127 • Stafford, Texas 77497-2127
 (281) 240-0440 • Fax: (281) 240-2440

Scale: _____ **Date:** _____
 Drawing #: _____
 Revision #: _____
 Drawn By: **DMC**
 Ck'd By: _____
 Certified By: _____
 Model #: _____