

REFLEX PRESSURE RATINGS AT ° F						
MID PRESSURE GAGE						
Glass Size	100°	200°	300°	400°	500°	600°
1	3000	2900	2800	2690	2500	2220
2	2910	2820	2720	2600	2420	2150
3	2820	2720	2625	2530	2350	2080
4	2725	2640	2560	2460	2270	2040
5	2630	2540	2460	2360	2190	1950
6	2535	2450	2360	2270	2110	1875
7	2440	2360	2280	2190	2030	1805
8	2345	2270	2190	2110	1960	1740
9	2250	2180	2100	2020	1880	1670

TRANSPARENT PRESSURE RATINGS AT ° F						
MID PRESSURE GAGE						
Glass Size	100°	200°	300°	400°	500°	600°
1	2500	2420	2340	2240	2080	1850
2	2315	2250	2170	2090	1940	1720
3	2130	2060	1990	1910	1770	1575
4	1940	1875	1810	1740	1620	1435
5	1750	1690	1630	1570	1460	1295
6	1565	1510	1460	1400	1305	1160
7	1375	1330	1280	1230	1145	1015
8	1190	1150	1110	1065	990	880
9	1000	970	935	895	835	740

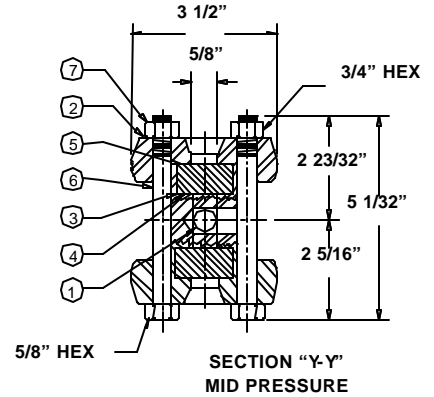
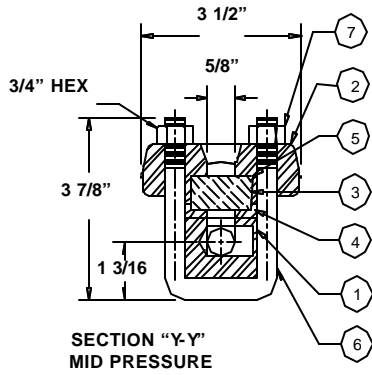
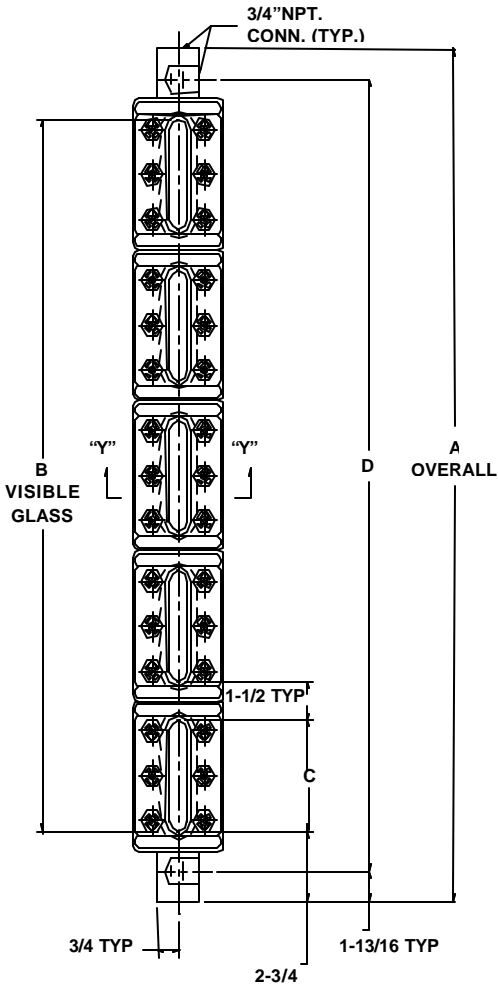

ITEM NO.	NAME	CARBON STEEL	STAINLESS STEEL WETTED
1	CHAMBER	CARBON STEEL	316L SS
2	COVER	CARBON STEEL	CARBON STEEL
3	GLASS	TEMPERED	TEMPERED
8	SHIELD	AS REQUIRED	AS REQUIRED
4	GASKET	NON-ASBESTOS	NON-ASBESTOS
5	CUSHION	NON-ASBESTOS	NON-ASBESTOS
6	BOLT	ASTM A193 B7	ASTM A193 B7
7	NUT	ASTM A194 2H	ASTM A194 2H

SIZE NO.	NUMBER OF SECTIONS					NUMBER OF SECTIONS					DIM "C" IN INCHES	NUMBER OF SECTIONS				
	DIMENSION "A" IN INCHES					DIMENSION "B" IN INCHES						DIMENSION "D" IN INCHES				
	1	2	3	4	5	1	2	3	4	5		1	2	3	4	5
1	9 1/4					3 3/4					3 3/4	5 5/8				
2	10 1/4					4 3/4					4 3/4	6 5/8				
3	11 1/4	18 1/2				5 3/4	13				5 3/4	7 5/8	14 7/8			
4	12 1/4	20 1/2				6 3/4	15				6 3/4	8 5/8	16 7/8			
5	13 3/8	22 3/4				7 7/8	17 1/4				7 7/8	9 3/4	19 1/8			
6	14 5/8	25 1/4	35 7/8			9 1/8	19 3/4	30 3/8			9 1/8	11	21 5/8	32 1/4		
7	15 3/4	27 1/2	39 1/4	51	62 3/4	10 1/4	22	33 3/4	45 1/2	57 1/4	10 1/4	12 1/8	23 7/8	35 5/8	47 3/8	59 1/8
8	17 3/8	30 3/4	44 1/8	57 1/2	70 7/8	11 7/8	25 1/4	38 5/8	52	65 3/8	11 7/8	13 3/4	27 1/8	40 1/2	53 7/8	67 1/4
9	18 1/8	32 1/4	46 3/8	60 1/2	74 5/8	12 5/8	26 3/4	40 7/8	55	69 1/8	12 5/8	14 1/2	28 5/8	42 3/4	56 7/8	71

Customer _____
 Cust. P. O. #: _____
 Factory #: _____
 Rep P.O. #: _____
 Assembled _____ "Centers"
 Tag #'s: _____

LEVEL GAGE 120-14
SERIES "M"
REFLEX & TRANSPARENT
CLOSE HOOKUP - 3/4" NPT CONN

The New Standard of Level

P.O. Box 2127 • Stafford, Texas 77497-2127
 (281) 240-0440 • Fax: (281) 240-2440

Scale: _____ **Date:** _____
 Drawing #: _____
 Revision #: _____
 Drawn By: **DMC**
 Ck'd By: _____
 Certified By: _____
 Model #: _____