

REFLEX PRESSURE RATINGS AT ° F						
HIGH PRESSURE GAGE						
Glass Size	100	200	300	400	500	600
1	4000	3860	3735	3580	3330	2960
2	3850	3720	3590	3440	3210	2850
3	3750	3620	3500	3355	3120	2775
4	3600	3465	3360	3220	3000	2660
5	3500	3360	3260	3120	2900	2580
6	3360	3240	3135	3010	2800	2490
7	3240	3120	3020	2900	2700	2400
8	3120	3020	2910	2790	2600	2310
9	3000	2900	2800	2690	2500	2220

TRANSPARENT PRESSURE RATINGS AT ° F						
HIGH PRESSURE GAGE						
Glass Size	100	200	300	400	500	600
1	3000	2900	2805	2690	2500	2220
2	2900	2800	2710	2600	2420	2145
3	2750	2660	2570	2465	2295	2035
4	2600	2515	2430	2330	2170	1925
5	2500	2420	2340	2240	2080	1850
6	2380	2280	2200	2120	1970	1745
7	2250	2165	2090	2010	1865	1660
8	2120	2050	1980	1900	1770	1570
9	2000	1935	1870	1790	1670	1480

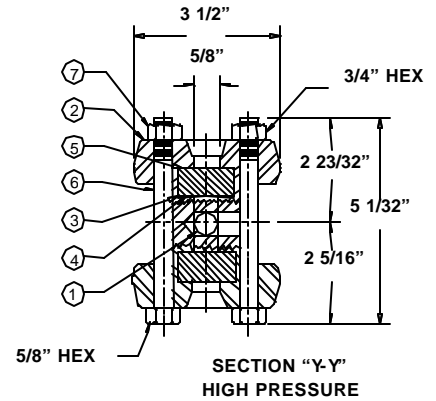
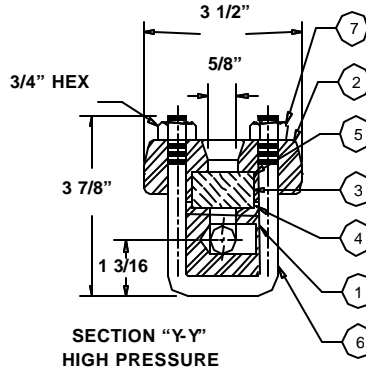
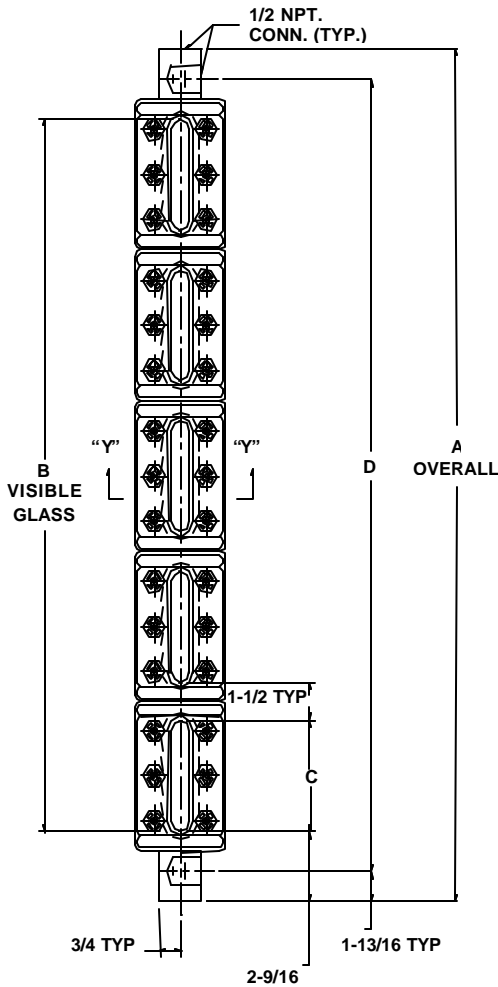

ITEM NO.	NAME	CARBON STEEL	STAINLESS STEEL WETTED
1	CHAMBER	CARBON STEEL	316L SS
2	COVER	CARBON STEEL	CARBON STEEL
3	GLASS	TEMPERED	TEMPERED
8	SHIELD	AS REQUIRED	AS REQUIRED
4	GASKET	NON-ASBESTOS	NON-ASBESTOS
5	CUSHION	NON-ASBESTOS	NON-ASBESTOS
6	BOLT	ASTM A193 B7	ASTM A193 B7
7	NUT	ASTM A194 2H	ASTM A194 2H

SIZE NO.	NUMBER OF SECTIONS DIMENSION "A" IN INCHES					NUMBER OF SECTIONS DIMENSION "B" IN INCHES					DIM "C" IN INCHES	NUMBER OF SECTIONS DIMENSION "D" IN INCHES				
	1	2	3	4	5	1	2	3	4	5		1	2	3	4	5
1	8 7/8					3 3/4					3 3/4	5 1/4				
2	9 7/8					4 3/4					4 3/4	6 1/4				
3	10 7/8	18 1/8				5 3/4	13				5 3/4	7 1/4	14 1/2			
4	11 7/8	20 1/8				6 3/4	15				6 3/4	8 1/4	16 1/2			
5	13	22 3/8				7 7/8	17 1/4				7 7/8	9 3/8	18 3/4			
6	14 1/4	24 7/8	35 1/2			9 1/8	19 3/4	30 3/8			9 1/8	10 5/8	21 1/4	31 7/8		
7	15 3/8	27 1/4	38 7/8	50 5/8	62 3/8	10 1/4	22	33 3/4	45 1/2	57 1/4	10 1/4	11 3/4	23 1/2	35 1/4	47	58 3/4
8	17	30 3/8	43 3/4	57 1/8	70 1/2	11 7/8	25 1/4	38 5/8	52	65 3/8	11 7/8	13 3/8	26 3/4	40 1/8	53 1/2	66 7/8
9	17 3/4	31 7/8	46	60 1/8	74 1/4	12 5/8	26 3/4	40 7/8	55	69 1/8	12 5/8	14 1/8	28 1/4	42 3/8	56 1/2	70 5/8

Customer \_\_\_\_\_  
 Cust. P. O. #: \_\_\_\_\_  
 Factory #: \_\_\_\_\_  
 Rep P.O. #: \_\_\_\_\_  
 Assembled \_\_\_\_\_ "Centers"  
 Tag #'s: \_\_\_\_\_

**LEVEL GAGE 120-15**  
**SERIES "H"**  
**REFLEX & TRANSPARENT**  
**CLOSE HOOKUP - 1/2" NPT CONN**



P.O. Box 2127 • Stafford, Texas 77497-2127  
 (281) 240-0440 • Fax: (281) 240-2440

Scale:		<b>Date:</b>
Drawing #:		
Revision #		
Drawn By:	<b>DMC</b>	
Ck'd By:		
Certified By:		
Model #:		