

## ST-600 STEAM-TRAC DIRECT READING STEAM/WATER GAGES For 600 PSI Working Steam Pressure (WSP)

- Fully compliant with ASME as a Direct Reading Water Gage
- Multiple sections with minimum 1" overlap
- Spring washers for constant torque
- Recessed gasket face in chamber and cover
- Custom built per specifications
- Studs, nuts and washers are yellow cadmium plated
- High temperature coating

Steam-Trac ST-600 steam gages are ruggedly built to set the industry standard for reliability. All materials and construction standards are within strict compliance of ASME Section 1 code requirements.

The Steam-Trac ST-600 can be configured to replace less durable, more expensive, competitive models or for specific construction projects. Visible range must be achieved by using multiple sections with a 1" minimum overlap to ensure continuous visibility, as required by ASME Section 1, PG-60.

To reduce expensive maintenance cycles, the Steam-Trac ST-60 is built with a gage chamber that is reinforced with internal tie bars to minimize lateral deflection of the gage chamber which is the primary cause of gasket or mica failure in steam gages. Consistent load on the gage cover is ensured with the liberal use of spring washers.

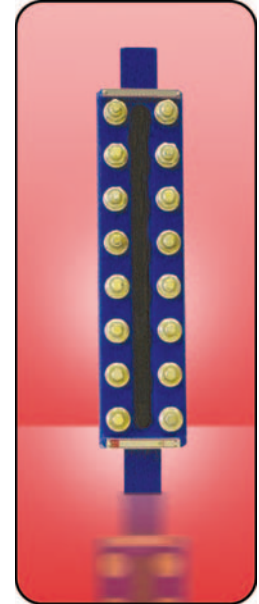

### Standard Materials

- Chamber: A-105, Grade 70 Carbon Steel
- Gasket: Grafoil® GHR
- Shield: HQ Mica
- Glass: Tempered Borosilicate
- Cover: Forged
- Washers: 17-7 PH Stainless Steel, Cadmium Plated
- Studs: A193-B7, Cadmium Plated
- Nuts: A194-2H, Cadmium Plated

Single Section Gages		
Model	Visible Glass	
	inches	mm
ST-600-61	9 1/8	232
ST-600-71	10 1/4	260
ST-600-81	11 7/8	302
ST-600-91	12 5/8	321

Multiple Section Gages		
Model	Maximum Visible Glass	
	inches	mm
ST-600-62	17 1/4	438
ST-600-72	19 1/2	495
ST-600-82	22 3/4	578
ST-600-92	24 1/4	616
ST-600-73	28 3/4	730
ST-600-83	33 5/8	854
ST-600-93	35 7/8	911
ST-600-74	38	965
ST-600-84	44 1/2	1130
ST-600-94	47 1/2	1207
ST-600-85	55 3/8	1407
ST-600-95	59 1/8	1502

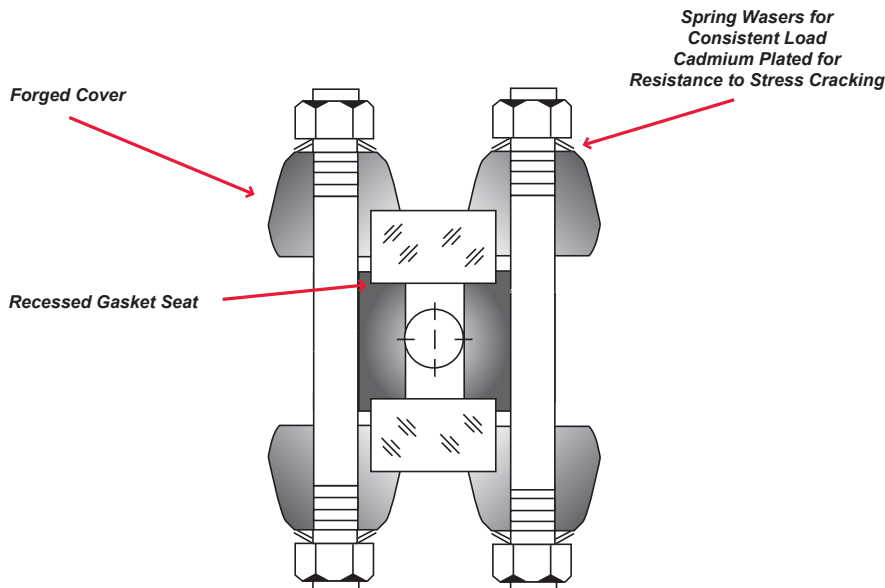

# STEAM-TRAC ST-600 STEAM/WATER GAGES - 600 PSI WSP

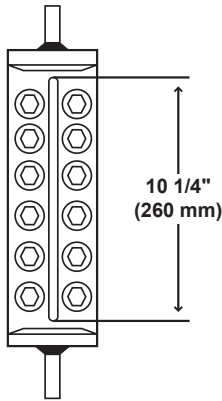

The minimum size of a single insert is 10 1/4" visibility. Standard Size 7 Glass.

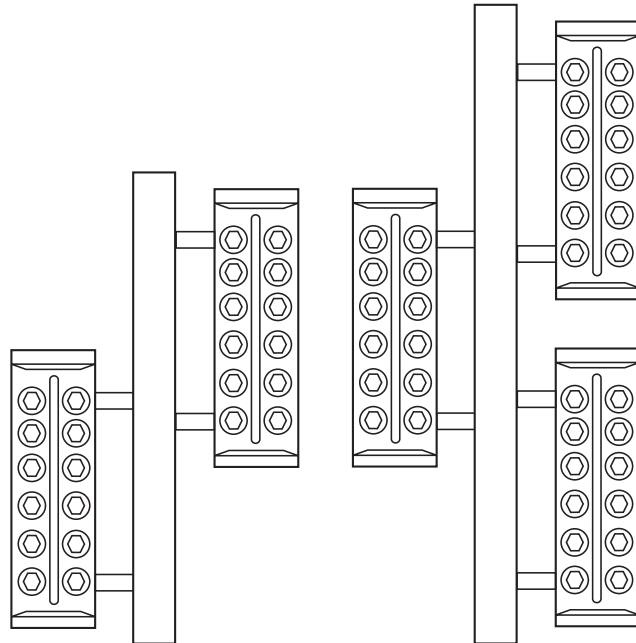

Gage inserts can be mounted on a center-tube to meet any visible range requirement.

*Ask us about adding alarms to the center-tube!*

## Model Number:

**ST - 600 - 74 - TB - 06 - N**

### Connection Location

TB = Top/Bottom Connected  
 SS = Side/Side Connected  
 SB = Top Side/Bottom End Connected  
 TS = Top End/Bottom Side Connected

### Connection Size

04 = 1/2"  
 06 = 3/4"  
 08 = 1"

### Connection Type

T = Threaded  
 S = Socket Weld  
 U = Union  
 F = Flanged  
 N = 304 SS Stuffing Box Nipples  
 (3/4" Top/Bottom Only)

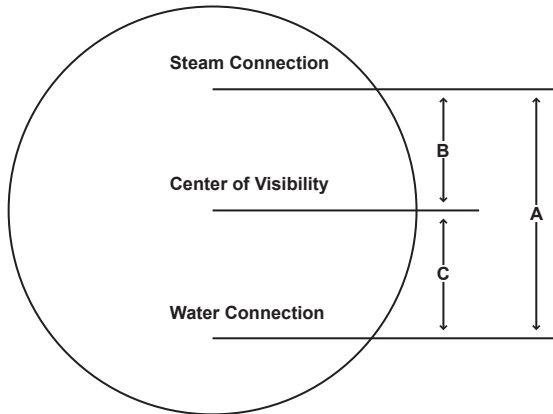

### Dimensional Information Required:

- A = Steam Water Centers  
 Please indicate any valve or expansion loop requirements.  
 And
- B = Center of Visibility to Steam Connection  
 Or
- C = Center of Visibility to Water Connection

The following information is required for prompt, accurate cost quotations and order processing:

- Maximum Operating Steam Pressure
- Steam Water Connection Size and Type
- Other Plant Piping Tie-Ins
- Gage Valve Requirements