

# STEAM-TRAC ST-1600

## Direct Reading Steam/Water Level Gage For 1600 PSI Working Steam Pressure (WSP)

- Fully compliant with ASME as a Direct Reading Water Gage
- Multiple sections with minimum 1" overlap
- Spring washers for constant torque
- Recessed gasket face in chamber and cover
- Custom built per specifications
- Studs, nuts and washers are nickel plated
- High temperature coating

Steam-Trac ST-1600 steam gages are ruggedly built to set the industry standard for reliability in the difficult mid-pressure range from 1000 to 1600 PSI Working Steam Pressure. All material and construction standards are within strict compliance of ASME section 1 code requirements.

The Steam-Trac ST-1600 can be configured to replace less durable, more expensive competitive models or for specific construction products. Visible range must be achieved by using multiple sections with a minimum 1" overlap to ensure continuous visibility, as required by ASME Section 1, PG-60.



### Standard Materials

Chamber: A516, Grade 70 Carbon Steel  
 Gasket: Grafoil® GHR  
 Shield: HQ Mica  
 Glass: Tempered Borosilicate  
 Cover: A516, Grade 70 Carbon Steel  
 Washers: 17-7PH Stainless Steel, Nickel Plated  
 Studs: A193-B7, Nickel Plated  
 Nuts: A194-2H, Nickel Plated

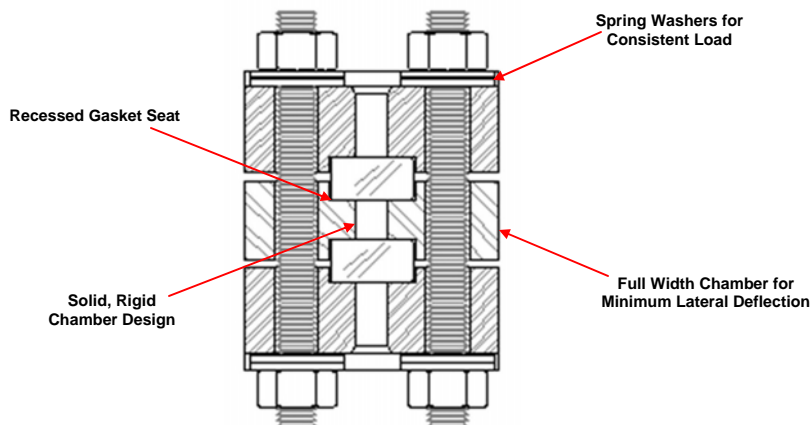

Single Section Gages		
Visible Glass	Model	
	inches	mm
9	229	ST-1600-61
10 1/8	257	ST-1600-71
11 3/4	298	ST-1600-81
12 1/2	318	ST-1600-91

Multiple Section Gages		
Visible Glass	Model	
	inches	mm
17	432	ST-1600-62
19 1/4	489	ST-1600-72
22 1/2	572	ST-1600-82
24	610	ST-1600-92
28 3/8	721	ST-1600-73
33 1/4	845	ST-1600-83
35 1/2	902	ST-1600-93
37 1/2	953	ST-1600-74
44	1118	ST-1600-84
47	1194	ST-1600-94
54 3/4	1391	ST-1600-85
58 1/2	1486	ST-1600-95

# ST-1600 STEAM-TRAC DIRECT READING STEAM/WATER GAGES

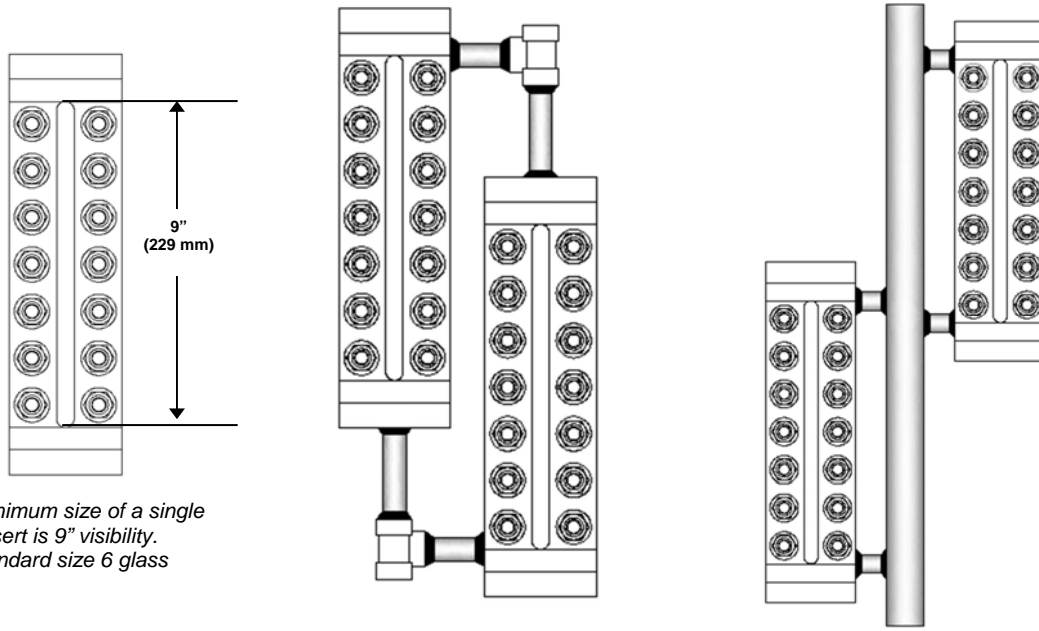

The minimum size of a single insert is 9" visibility. Standard size 6 glass

Gage inserts can be mounted on a center tie-tube to meet any visible range requirement

**Connection Location**  
 TB = Top/Bottom Connected  
 SS = Side/Side Connected  
 SB = Top Side/Bottom End Connected  
 TS = Top End/Bottom Side Connected

**ST - 1600 - 74 - TB - 04 - U**

**Connection Size**  
 04 = 1/2"  
 06 = 3/4"  
 08 = 1"  
 12 = 1 1/2"  
 16 = 2"

**Connection Type**  
 T = Threaded  
 S = Socket Weld  
 U = Uniflex Union  
 F = Flanged  
 N = 304 SS Stuffing Box Nipples (3/4" Top/Bottom Only)  
 L = Expansion Loop

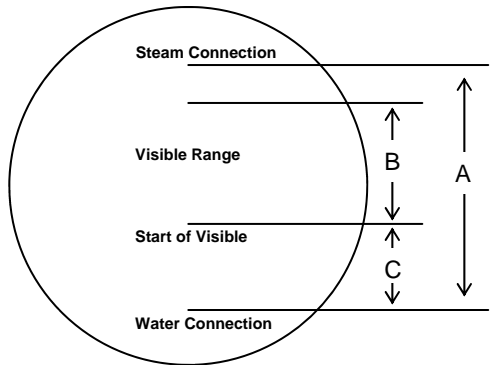

**Dimensional Information Required:**  
 A = Steam Water Centers Please indicate any valve or expansion loop requirements.  
 And  
 B = Visible Range  
 And  
 C = Start of Visibility

The following information is required for prompt, accurate cost quotations and order processing:

- Maximum Operating Steam Pressure
- Steam Water Connection Size and Type
- Other Plant Piping Tie-Ins
- Gage Valve Requirements



ISO 9001:2008  
 Quest-Tec Solutions



Address: 13960 S. Wayside · Houston, TX · 77048  
 Toll Free Tel: 866.240.9906 · Tel: 281.240.0440 · Fax: 281.240.2440  
 www.QTSLevel.com · sales@QTSLevel.com