



Questtec
SOLUTIONS

LEVEL-TRAC & STEAM-TRAC

HRSG Drums, Boilers, Heaters, De-Aerators, Condensers Level Gage and
Level Switch Direct and Indirect Per PG60.1

LEVEL-TRAC & STEAM-TRAC

TURBINE

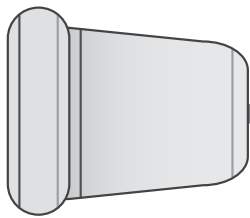

BOILER

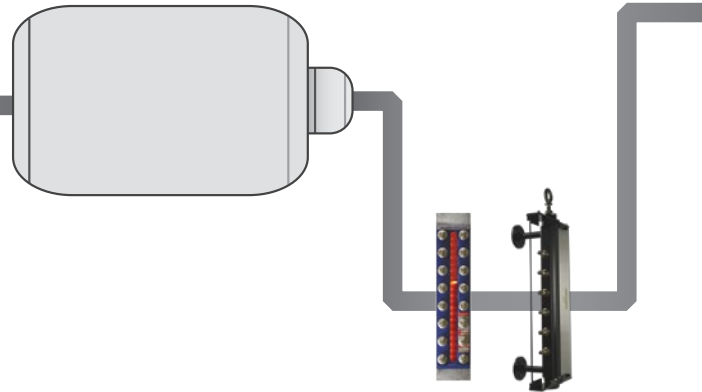

WATER LEVEL MEASUREMENT

THE PRINCIPLES UNDERLYING THE PRODUCT

Reliable detection of condensate levels within boiler drums is one of the most critical measurements required in a steam generation plant.

Low condensate levels can damage boiler tubes while high condensate levels can damage steam turbines. These are catastrophic events that result in significant maintenance costs, but are fully preventable with the right safeguards.

Fortunately, steam and condensate have distinct electrical properties. Condensate is far more conductive (and less resistive) than steam. Boilers produce a wide range of condensate conductivities within their drum and piping systems. These simple properties can be leveraged to provide accurate, reliable measurement of condensate levels through two different approaches: conductivity and resistivity. Questtec offers both in our indirect gages.

CONDUCTIVITY

The conductivity approach utilizes a series of switches to determine the drum's condensate level. A control unit houses detection modules that deliver a low voltage signal to probe tips in a water column. When a probe tip is submerged in condensate, its circuit is completed and two sets of DPDT "Form C" Dry contacts change state. By reading the probes switches and noting their locations, the condensate level is apparent.

The Level-Trac LT-100 Series is based on this principle and supports any number of horizontally or vertically mounted probes. The standard control units come in 50 kΩ sensitivity, and are also available in 25 or 75 kΩ. The 11 pin module plug in design is easily replaceable in the field by hand. An optional remote indicator may be mounted up to 500 ft away in a Fiberglass Reinforced Polycarbonate Nema-4X enclosure or control panel mount.

RESISTIVITY

The resistivity approach is a more technically nuanced approach that measures electrical resistance to determine condensate levels. Resistivity between condensate and steam is measured in a calibrated cell of the water column. The cell dimensions create a calibrated resistance typically greater than or equal to 0.1 MΩ when condensate is absent. When condensate is present, the resistance in the cell drops below 0.1 MΩ. A resistivity circuit is arranged to sense whether the probe resistance is less than or greater than the 0.1 MΩ mark within a series of cells to determine how many contain condensate. The condensate level in the drum becomes apparent in a manner similar to the conductivity system. The detection level is independent of water purity and boiler operating conditions.

The Level-Trac LT-210, LT-230, LT-302 and LT-310 Series Electronics are based on this principles. As there is a continual live signal on every channel, this system offers engineered redundancy with fault tolerant fail safe operation. A push-to-test button completely tests the electronics integrity and system's operation, a feature that aids in troubleshooting. Questtec can fulfill your level measurement needs on the principle of conductivity or resistivity.

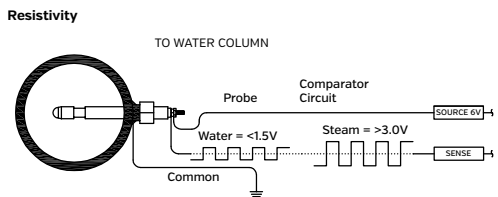
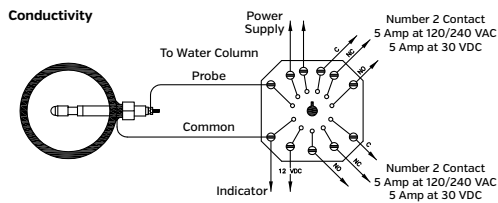

HEATERS

DEAERATOR

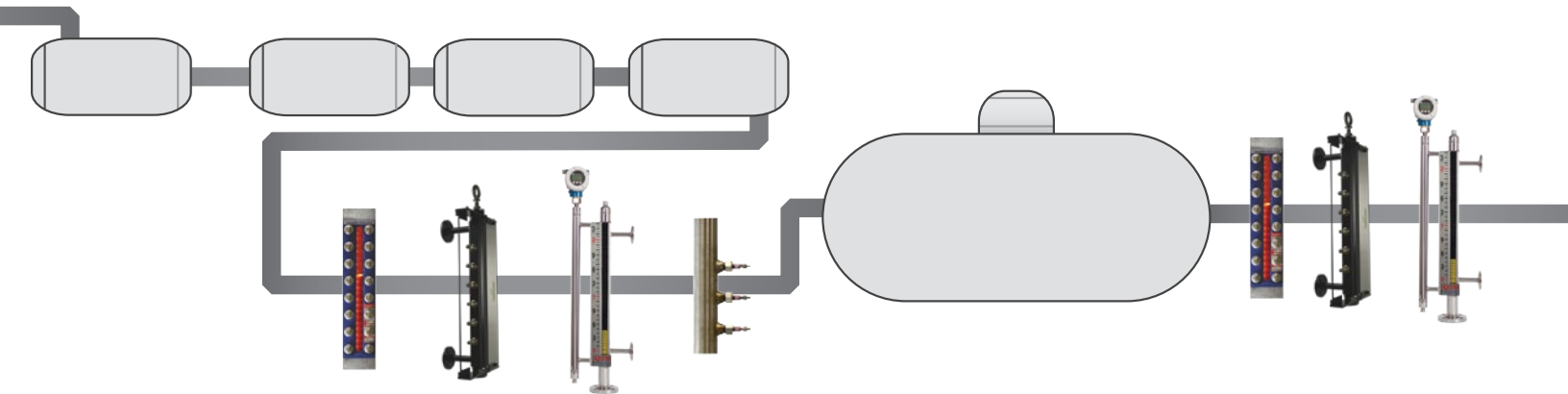

TURBINE WATER INDUCTION PREVENTION

DIRECT AND INDIRECT PER PG60.1

All normally operating steam turbines carry the inherent risk of water ingress. Small amounts of condensate can enter from any connection to the turbine, sometimes arising rapidly from the condensation of steam.

This almost always results in catastrophic damage to the turbine, even in low pressure situations. Human operators are rarely able to recognize and prevent these problems as quickly as they occur. Therefore, automatic turbine water induction prevention (T.W.I.P.) systems must be used to safeguard turbines from this danger. They save significant costs through quick detection and prevention of water ingress into the steam turbine.

THE QUESTTEC SOLUTION

Questtec offers a range of products to safeguard your system with T.W.I.P. Safe plant operation begins with a the LT-210 or LT-230 system installed on the boiler drum with high alarms and high trips set and continues with the LT-302 or LT-310 on Heater Drains, Superheat and Reheat Main Drains, and on Drip Pots downstream of Attemperators. This will monitor all potential areas for turbine water induction and automatically detect it. Our products fulfill ASME recommendations for safe steam turbine operation made in the TDP-1-2006 Standard.

The LT-302/310 Series' works on the same principles as the high integrity LT-210/230 Series Resistivity and is selected where 1-6 probe channels are required. A single probe can be utilized to provide a control signal or several can be paired and validated against each other where greater reliability is demanded. It offers a sensitivity that is reliably able to detect condensate down to 0.5 mS/cm² instantly.

The circuits are in a continual state of test, with any faults reported through relay contacts and a visual indicator mounted on the front panel. The system can be set up such that no failed individual probe or component can cause a false signal, thereby always maintaining the critical functionality of the probes.

STANDARD FEATURES

Questtec includes a number of standard features in all T.W.I.P. products to ensure easy operation and maintenance. Standard features include: Alarms & Validated Tripping Relays, Normally Energized or Deenergized Relays, Time Delays, Sensitivities Settings, LED flash. All are easily set with solder pads in the field or by Questtec before delivery. Products also include an electronics integrity test button that tests the entire system's operation.

T.W.I.P. applications are standard in many respects, but engineered pressure parts are typically custom built to customer specifications to minimize installation costs. Trust Questtec's high quality equipment to provide T.W.I.P. so you can operate your steam turbines safely and efficiently.

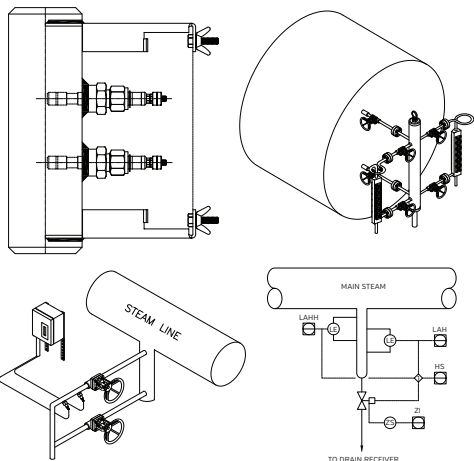

LEVEL-TRAC & STEAM-TRAC

DIRECT READING GAGES

The Questtec Steam-Trac product line fully complies with the ASME Section I requirement for Direct Reading Gage Glass. Steam-Trac products are designed specifically for the rigorous service condition of steam generation, and consistently yield lower maintenance cost than competitive products.

350
PSI



ST-350

Chamber: A-696 GR.C, Carbon Steel
Gasket: Grafoil® GHR
Glass: Reflex, Tempered Borosilicate
Cover: Forged Carbon Steel
U-Bolts: A193-B7
Nuts: A194-2H
Spring Washers: 17-7 PH SST Nickel Plated

450
PSI



ST-450

Chamber: A-696 Grade C Carbon Steel
Gasket: Grafoil® GHR
Shield: HQ Mica
Glass: Transparent, Tempered Borosilicate
Cover: Forged Carbon Steel
Studs: A193-B7
Nuts: A194-2H
Spring Washers: 17-7 PH SST Nickel Plated

1000
PSI



ST-1000

Chamber: A-105 Carbon Steel
Gasket: Grafoil® GHR
Shield: HQ Mica
Glass: Transparent, Tempered Borosilicate
Cover: Forged Carbon Steel
Studs: A193-B7
Nuts: A194-2H
Spring Washers: 17-7 PH SST Nickel Plated

1600
PSI



ST-1600

Chamber: A516 Grade 70 Carbon Steel
Gasket: Grafoil® GHR
Shield: HQ Mica
Glass: Transparent, Tempered Borosilicate
Cover: A516 Carbon Steel
Studs: A193-B7
Nuts: A194-2H
Spring Washers: 17-7 PH SST Nickel Plated

3000
PSI



STB-3000A

Chamber: 304 SS Single-piece Extruded
Gasket: Spiral Wound Grafoil
Shield: Ruby HQ Mica
Glass: Ported, Tempered Aluminosilicate
Cover: Carbon Steel
Bolts: A193-B7
Bi-color Illuminator Required per ASME Boiler Code



SLI-A SEE-LEVEL ILLUMINATOR FOR STEAM SERVICE

Lighting: Amber LED's angled at 45° for easy viewing of meniscus

Power Supply: 115 or 230 VAC @ 50/60 HZ

Power Consumption: <150 mA @ 115 VAC

Supply Connection: 3/4 NPT

Ambient Temp: -40°F [-40°C] to 150°F [65°C]

LED Estimated Life: 100,000 hours

Certification: UL1203, UL913, CSA22.2, CL I, DIV 1, Groups B, C, & D, NEMA 4X & 8



STBI-3000A BI-COLOR ILLUMINATOR

Power Supply: 84-264 VAC

Power Consumption: 0.24 Amps per 5 Ports

Power Supply Enclosure: NEMA 4X, Anodized Aluminum

Lighting: Long Life, Low Current, High Intensity, LED Lamps, Indoor Application, Frosted Glass

Material: Anodized Aluminum

Connection Type: Quick Connect Latches for Ease of Assembly

Certification: NEMA 4X

Optional: Class I, Division 1, Groups B, C, & D

SUN VISOR

AMBIENT OUTDOOR ASSEMBLY
[Clear Glass Front & High Temp Black Front]

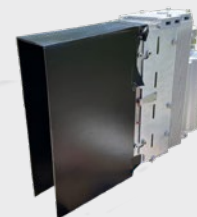

CUSTOM DESIGNED LEVEL MEASUREMENT PRODUCTS



ST-450 with Illuminator and Equalizer Tube



ST-350 with Magne-Trac Magnetic level Gage



316 SS STB-3000A



ST-1000 and Illuminator with Bridle-Trac and Guided Wave Radar

VALVES

Questtec Solutions steam valves are designed specifically for use with water level gages in steam/water service. The angled flow path compactly facilitates installation of the level gage, bringing the assembly connection point to the side. Each model is designed to prevent steam galling and maximize packing life to extend the longevity of the valve.

**450
PSI**



SV-450

- Offset Pattern
- Grafoil Packing for Temperatures to 700°F
- Union Bonnet
- Removable Seat
- Solid Shank Connector
- Optional Back-seating Stem

VALVE OPTIONS

- Gasketed Union Gage Connection to allow rotation of viewing angle
- Quick-Closing Levers
- Chainwheel Operation
- Vertical Rising Ball Check

**1100
PSI**



SV-1100

- Offset Pattern
- Outside Screw & Yoke [OS&Y] Design
- Non-Union Solid Shank Tank Connector
- Bolted Bonnet
- Grafoil Packing for Temperatures to 700°F
- Non-rotating Back-seating Stem

GAGE OPTIONS

- Isolation or Drain Valves per customer requirements
- Gasketed Union Gage Connection to allow rotation of viewing angle
- Stainless Steel Construction for Offshore or Corrosive Environments
- Center Tie-Tube to Meet Any Visible Range

**1600
PSI**



SV-1600A

- Offset Pattern
- Outside Screw & Yoke [OS&Y] Design
- Non-Union Solid Shank Tank Connector
- Bolted Bonnet
- Grafoil Packing for Temperatures to 700°F
- Non-rotating Back-seating Stem

COLUMN OPTIONS

- Isolation or Drain Valves per customer requirements
- Pre-wired, Integral Mounted Junction Box
- 30 ft Cable Bundle
- Alternate Materials Available for Corrosive Environments and Extreme Temperatures

**3000
PSI**



SV-3000

- Outside screw & yoke design
- Back Seating Stem
- Graphite packing
- High performance packing system
- Integral Gland Wrench
- Clampseal Bonnet/Chamber

READY TO SPEC?

The following is an overview of **Questtec Solution's** standard steam products. For more in depth information, contact your Questtec Sales Representative. You can also contact Questtec directly by phone at 866-240-9906, by email at sales@qtslevel.com, or online at:

questtecsolutions.com



INDIRECT GAGES

Questtec Solutions Level-Trac products are designed exclusively to sense water in steam generation process. Level-Trac systems include remote water level indicators per ASME Section I and turbine water induction protection.

**1000
PSI**



LT-500
Chamber: SA-105 Extruded
Probe Mounting: Horizontal
Probe Type: Type 800
Probe Gasket: Spiral Wound



TYPE 800
Probe Rating: 1000 PSI WSP; 550°F
 Threaded Column Connection High Quality
 Spiral Wound Gasket
 TFE Insulator

**2000
PSI**



LT-501
Chamber: SA-105 Extruded
Probe Mounting: Horizontal
Probe Type: 810
Probe Gasket: Spiral Wound



PROBE 810
Probe Rating: 2000 PSI WSP; 1100°F
 Threaded Column Connection
 Helium Leak Tested
 High Quality Spiral Wound Gasket
 Zirconium Insulator
 Ceramic to Metal Vacuum Brazing

**3000
PSI**



LT-502
Chamber: SA-106C Schedule 160
Probe Mounting: Horizontal
Probe Type: 820
Probe Seal: Ferrule Seat



PROBE 820
Probe Rating: 4350 PSI WSP; 1100°F
 Single Hex Nut Closure
 Helium Leak Tested
 Metal-to-metal Ferrule Seat
 Zirconium/Aluminosilicate Insulator
 Ceramic to Metal Vacuum Brazing

**4350
PSI**



LT-502+
Chamber: SA-106C Schedule XXS
Probe Mounting: Horizontal
Probe Type: 820
Probe Seal: Ferrule Seat

**1000
TO
2000
PSI**



LT-40 / LT-41
 Point Level Switch
 Installation Within Any Vertical Pipe Run Top/
 Bottom
 End Connections
 3/4" or 1", F.NPT or SW
 Chamber: A-106C Carbon Steel
 No. of Probes: 1-2
 Rating: 1,000 PSI [LT-40] 2,000 PSI [LT-41]
 [Recommended Control Unit: LT-302]



OEM ENHANCED PERFORMANCE KITS

Level-Trac probe replacement kits offer a better value as compared to original equipment manufacturers. Enhanced Performance kits are available for manufacturers such as:

- Clark Reliance
- Yarway/Fossil
- Diamond Power
- Hydrastep

**READY
TO SPEC?**

The following is an overview of **Questtec Solution's** standard steam products. For more in depth information, contact your Questtec Sales Representative. You can also contact Questtec directly by phone at 866-240-9906, by email at sales@qtslevel.com, or online at: questtecsolutions.com



ELECTRONIC CONTROL UNITS

LT-302

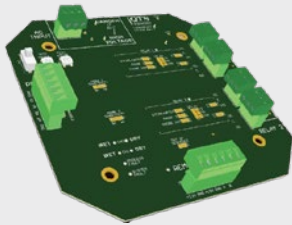

Probe Channels: 1 - 2
Relays: Two DPDT
Power Supply: Single 100 to 240 VAC
Enclosure: NEMA 4X Fiberglass Reinforced Polyester

Features: Low Voltage to Probes, Voting Logic Controlled Trip Circuits, System Fault Logic and Indication, Circuit Test Buttons
Options: Panel Mount & Remote Display High Temp Cable Stainless Steel Enclosure

LT-310

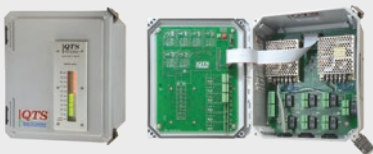

Features:

- Six Discrete Channels
- Six Field Assignable Auxiliary Relays
- Two Independent Power Supply Units
- Probe Cable Fault Monitoring
- No Maintenance or Routine Testing
- Fault Detection

Enclosure: NEMA4X/IP65 Wall mounted glass-fiber reinforced polyester
Power Supply: Dual 100-240 VAC \pm 10%, 48 - 63 Hz

Relay Outputs: Two Alarms; Two Validated Trips; One Fault; 2 out of 3 Probe channel voting circuit; Relay Rating: DPDT; Max. Current: 8 Amps @ 250VAC

LT-210



Features:

- One to Twelve Probe Channels
- 4-20mA Output Signal
- Field Programmable Alarm and Trip Points
- Voting Logic for Trips
- Serial Remote Display Signal
- Sequence Fault Detection

Enclosure: NEMA4X/IP65 Wall mounted glass-fiber reinforced polyester (stainless steel is available as an option)

Power Supply: Single 100-240 VAC \pm 10%, 48 - 63 Hz

Relay Outputs: Two Alarms; Two Validated Trips; One Fault; 2 out of 3 Probe channel voting circuit; Relay Rating: DPDT; Max Current: 8 Amps @ 250VAC

LT-230



LED indicator shown is up to 14 Channels

Features:

- Up to 36 Probe Channels
- 4-20mA Output Signal
- Programmable Alarm and Trip Points
- Voting Logic for Trips
- Serial Remote Display Signal
- Sequence Fault Detection
- LED Display on unit [optional]

Enclosure: NEMA4X/IP65 Wall mounted glass-fiber reinforced polyester (stainless steel is available as an option)

Power Supply: Single 100-240 VAC \pm 10%, 48 - 63 Hz

Options: LED Display on unit [optional]; Purge System available to meet Class 1 Div 2; Fiber Optic



REMOTE INDICATORS

Each of these electronic units are available with remote indicators. These remote indicators come with individual channel wiring and the LT-210 and LT-220 models have an option for serial transmission.

HIGH TEMPERATURE CABLING

Our cable is designed specifically for use with Level-Trac Remote Level Indicator Systems for connection of the probe column to the control unit. The probe side will be terminated with high temperature, nickel plated steel, un-insulated ring terminals for connection to the probes and common lug.

4-20MA LEVEL CONTROL UNITS



Programmable Control Unit for Guided Wave Radar

LT-420

FEATURES

- 4-20mA Output Signal
- Programmable Alarm & Trip Points from Guided Wave Radar
- Serial Remote Display Signal – Optional Fiber Optic
- Ability to power three remote indicators
- 4 – Relays, 8 AMP per relay
- ASME PG60.1.1.2 Code Compliant

Enclosure: NEMA4X/IP65 Wall mounted glass-fiber reinforced polyester (stainless steel is available as an option)

Power Supply: Single 100-240 VAC ± 10%, 48 – 63 Hz Optional 24 or 48 VDC

Options: Additional remote displays; Column ratings: Up to 3000psi maximum and 1200°F maximum Column materials: Carbon Steel, Stainless Steel and Chrome Moly; Auxiliary relay module



Dynamic Water Density Compensation

LT-440

FEATURES

- NEMA 4X Fiberglass Reinforced Polyester Enclosure
- 100-240 VAC 48-63 Hz Power Supply
- Data Collected from (4) Thermocouple inputs to correct water density error
- Loop input for drum temperature
- System Fault Logic and Indication
- Low Power Consumption, 0.25 Amp Maximum

Alarm and Trip Logic: Four DPDT relays for alarm and trip actuation; Dedicated DPDT relay to be programmed and used as the application requires; Door mounted indicator

Fault Logic: Illuminate if a thermocouple zeros or exceeds a given set point; any individual thermocouple that indicates a failure will be ignored when estimating water temperature.

FMP54 ACCESSORY

Continuous measurement in liquids under extreme conditions. Excellent for steam boilers, toxic media using gas tight feed-through guarantee. Reliable results in case of gas and steam phases. Reliable in moving surface, foam and changing medias.



FEATURES

Process connections	Thread or flange
Temperature	-196 to +450°C [-320 to +842°F]
Pressure	Vacuum -1 to +400bar (Vacuum -14.5 to +5,800psi)
Maximum measuring range	Rod 10m [33ft], Rope 45m [148ft], Coax 6m [20ft]
Accuracy	Rod ±2mm [0.08"]
Dielectric Constant	1.6 [Rod probe, Rope probe], 1.4 [Coax probe]

International explosion protection certificates, overfill prevention WHG, SIL, marine approval, steam boiler approval, 5-point linearity protocol

GWR SOLUTION

Eliminate Water Density Errors!

The Questtec LT-430 provides an exclusive means of achieving accuracy with Guided Wave Radar when used in a water column to determine level in a high pressure steam system. The LT-430 utilizes the data collected from at least 4 thermocouples installed on the water column and determines an actual average water temperature. The primary loop is dynamically corrected and a secondary loop is communicated to any device included in the loop.

MODERN BOILER LEVEL INDICATION

What challenges exist in high pressure steam service, when measuring water level?

Condensate Flow – What is the Error Potential?

Pressure	Temperature	Column Range	*Density Error %	*Density Error "inches" of H2O
2000 psi	636°F	60"	8%	4"
2500 psi	669°F	60"	12%	7"
3000 psi	696°F	60"	27%	18"

GUIDED WAVE RADAR BOILER LEVEL SYSTEM BREAKDOWN

- Temperature is Input
- Densities are Calculated
- Signal is Corrected

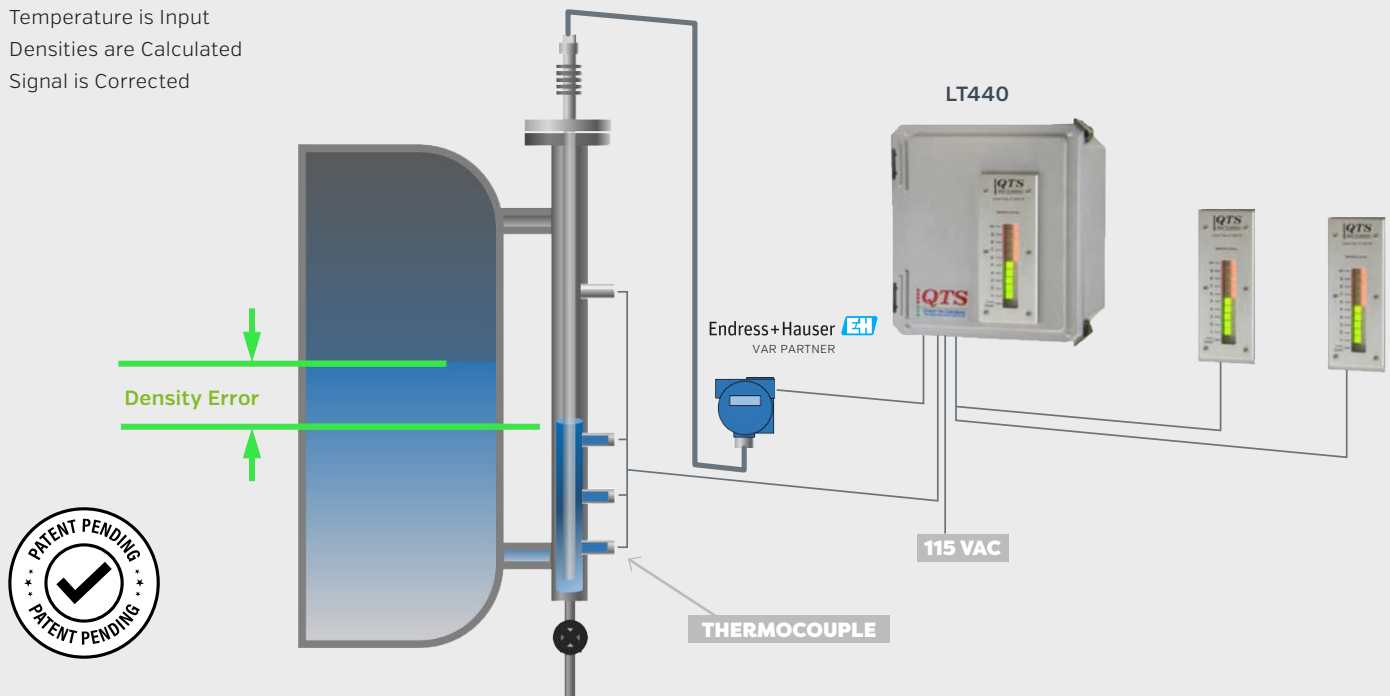

KEY FACTORS

- Value: Questtec Integrates a complete turn-key package
- Compliance to ASME Boiler Code as Remote Level Indicator "RLI"
- RLI must be a discrete system independent of the DCS control system
- RLI system monitors the boiler water level to independently validate signal for level controls
- Water Level continuously visible to operators with panel mount remote display
- LT-440 GWR control unit powers the GWR and displays the water level locally at the boiler
- Dedicated power supply provides clean power source, close proximity to transmitter
- [1] LT-440 can drive [3] remote displays with bar graphs
- Programable Relay Outputs
- Loop input for drum temperature

PROVEN GUIDED WAVE RADAR

- Receives PT signal for actual drum pressure
- Receives TE signal for actual temperature
- Local controller performs density error calculations: resulting bicolor local and remote indicators always indicated true density compensated level, regardless of pressure / temperature
- Meets ASME PG60.1.1.2*
- Level Gauge may be mounted to the column to declutter service area
- Associated accessories available: Hot/Cold Insulation, Steam Tracing, Block Valves, Vent/Drain Valves

* 2019 ASME PG60.1.1.2 reads... "when two independent remote water level indicators are in reliable operation [continuously indicating water level], the one required gage glass may be shut off, but shall be maintained in the serviceable condition"

INSTRUMENT BRIDLE SOLUTIONS

The QTS Bridle-Trac is an ideal means of utilizing the power of many technologies without mounting directly into the vessel.

The QTS Bridle-Trac external chamber is a self-contained cage designed for use with our top mounting level transmitters or switches. Quality construction and a wide selection of configurations make this cage an ideal means of utilizing the power of our many technologies without mounting directly into the process vessel. The chamber is suitable for use with Guided Wave Radar, RF Capacitance Transmitters, Electronic point sensors and top mounted displacer switches. In addition, mount Level Gages and Valves to your Instrument Bridle for ease of maintenance.

FEATURES

Sealed or flanged-top chamber options

2" and 4" nominal chamber diameters to accommodate all sensing elements

Carbon steel or 316 stainless steel materials of construction

Rugged Questtec commercial construction available as well as ASME B31.3, ASME B31.1, NACE or combined NACE and ASME B31.3 construction options

Rated for pressures up to 5000 psi [345 bar]

For applications to 842°F [450°C]

Lengths for measuring ranges to twenty feet [6.1 m]

Broad selection of process connections sizes and types

Head flange bolting included with flange-top models

Suitable for use with RF capacitance transmitters, all electronic point sensors and top mounted displacer switches

Optimal design for use with Guided Wave Radar transmitter:

- Smallest possible chamber diameters
- Pressure rating to match High Temperature, High Pressure (HTHP) and High Pressure (HP) probes
- Temperature rating to match HTHP probe
- Space above and below measuring range to accommodate measurement transition zones



ADVANTAGES

✓ Single point responsibility instruments, bridle, welding, testing, documentation

✓ Reduces turbulence & foam improves measurement accuracy

✓ Avoid interference between other devices

✓ Isolation ease of calibration and maintenance

SYSTEM SUMMARY

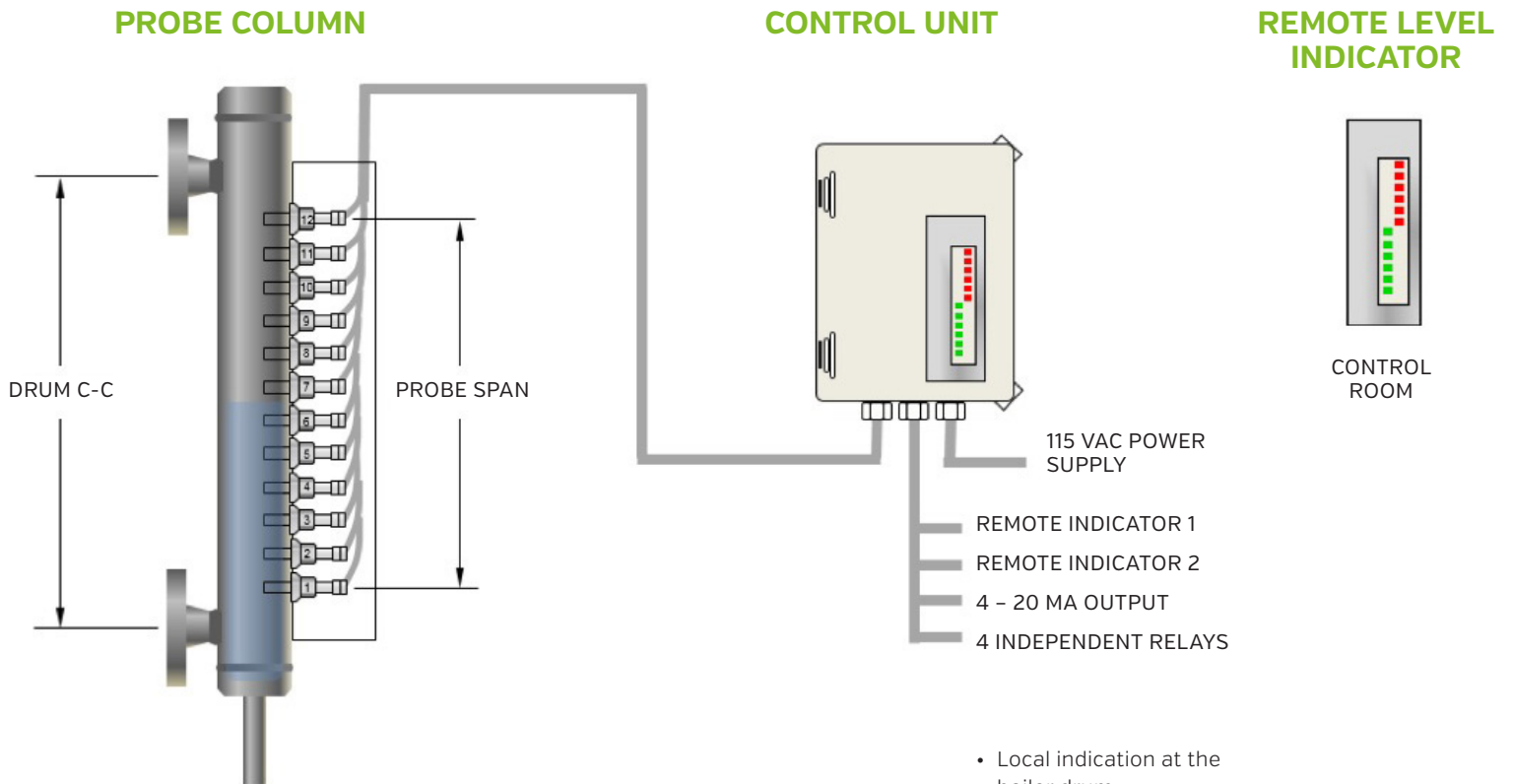

- Local indication at the boiler drum
- Remote indication for the control room
- [4] Relays for the switch points L/LL/H/HH
- 4-20mA Output

SPARE PARTS

Kits including glass, gaskets, cushions and shields are available for repair of Questtec or OEM direct reading gages.



Gaskets, cushions, glass & shields for reflex and transparent style gages

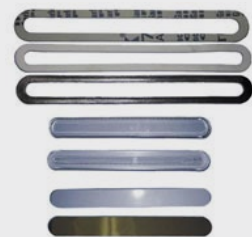

Glass, Gaskets, Cushions, & Mica Shields for STB-3000 Bi-Color Ported Gage



40,000FT² CLIMATE CONTROLLED

Questtec
SOLUTIONS

13960 S. Wayside Drive
Houston, Texas 77048

Toll Free: 866.240.9906

Tel: 281.240.0440

Fax: 281.240.2440

QTSLEVEL.COM

