

## STEAM-TRAC ST-450

### Direct Reading Steam/Water Level Gage

For 450 PSI Working Steam Pressure (WSP)

- Fully compliant with ASME as a Direct Reading Water Gage
- Multiple sections with minimum 1" overlap
- Spring washers for constant torque
- Recessed gasket face in chamber and cover
- Custom built per specifications
- Studs, nuts and washers are nickel plated
- High temperature coating

Steam-Trac ST-450 steam gages are ruggedly built to set the industry standard for reliability. All material and construction standards are within strict compliance of ASME section 1 code requirements.

The Steam-Trac ST-450 can be configured to replace less durable, more expensive competitive models or for specific construction products. Visible range must be achieved by using multiple sections with a minimum 1" overlap to ensure continuous visibility, as required by ASME Section 1, PG-60.



#### Standard Materials

- Chamber: A-696, Grade C Carbon Steel
- Gasket: Grafoil® GHR
- Shield: HQ Mica
- Glass: Tempered Borosilicate
- Cover: Forged Carbon Steel
- Washers: 17-7PH Stainless Steel, Nickel Plated
- Studs: A193-B7, Nickel Plated
- Nuts: A194-2H, Nickel Plated

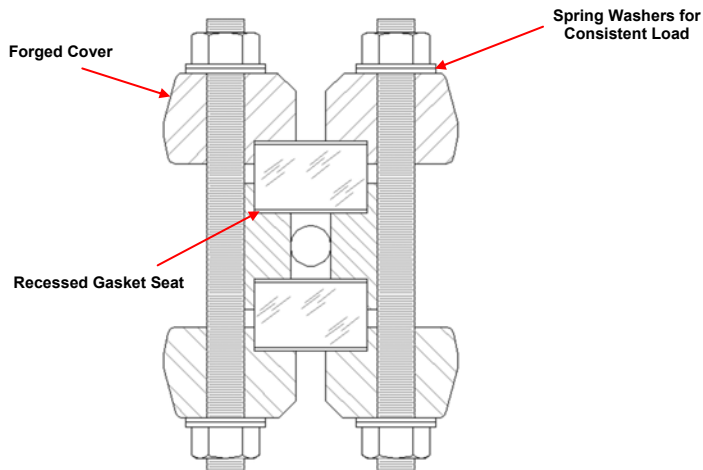

Single Section Gages		
Visible Glass		Model
inches	mm	
9 1/8	232	ST-450-61
10 1/4	260	ST-450-71
11 7/8	302	ST-450-81
12 5/8	321	ST-450-91

Multiple Section Gages		
Visible Glass		Model
inches	mm	
17 1/4	438	ST-450-62
19 1/2	495	ST-450-72
22 3/4	578	ST-450-82
24 1/4	616	ST-450-92
28 3/4	730	ST-450-73
33 5/8	854	ST-450-83
35 7/8	911	ST-450-93
38	965	ST-450-74
44 1/2	1130	ST-450-84
47 1/2	1207	ST-450-94
55 3/8	1407	ST-450-85
59 1/8	1502	ST-450-95

# ST-450 STEAM-TRAC DIRECT READING STEAM/WATER GAGES

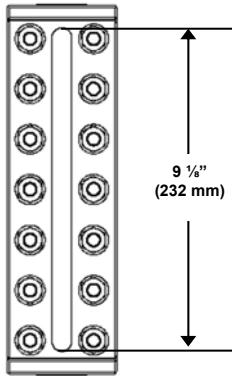

The minimum size of a single insert is 9 1/8" visibility.  
Standard size 6 glass

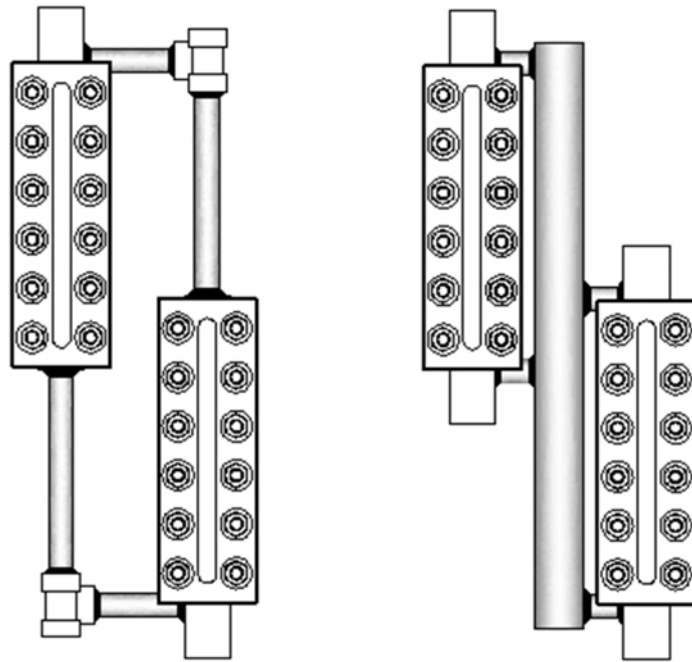

Gage inserts can be mounted on a center tie-tube to meet any visible range requirement

### Connection Location

TB = Top/Bottom Connected  
SS = Side/Side Connected  
SB = Top Side/Bottom End Connected  
TS = Top End/Bottom Side Connected

**ST - 450 - 74 - TB - 06 - S**

### Connection Size

04 = 1/2"  
06 = 3/4"  
08 = 1"  
12 = 1 1/2"  
16 = 2"

### Connection Type

T = Threaded  
S = Socket Weld  
U = Uniflex Union  
F = Flanged  
N = 304 SS Stuffing Box Nipples  
(3/4" Top/Bottom Only)  
L = Expansion Loop

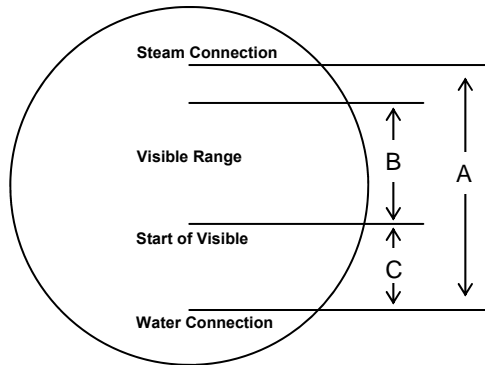

### Dimensional Information Required:

A = Steam Water Centers  
Please indicate any valve or expansion loop requirements.  
And  
B = Visible Range  
And  
C = Start of Visibility

The following information is required for prompt, accurate cost quotations and order processing:

Start of Visible

- Maximum Operating Steam Pressure
- Steam Water Connection Size and Type
- Other Plant Piping Tie-Ins
- Gage Valve Requirements

**Questtec**  
SOLUTIONS

The New Standard of Level

Glass-Trac      Level-Trac  
Steam-Trac      Magne-Trac

Address: 13960 S. Wayside · Houston, TX · 77048  
Toll Free Tel: 866.240.9906 · Tel: 281.240.0440 · Fax: 281.240.2440  
www.QTSLevel.com · sales@QTSLevel.com