

Bill of Materials

	Part	Material
1	Chamber	
2	Cover	
3	Glass	
4	Gasket	
4	Shield	
5	Cushion	
6	Bolt	
7	Washer	
8	Nut	

Notes

Dimensions

B

**Steam-Trac ST-1600**



**1-Section**

**Quest-Tec Solutions** *The New Standard of Level*

Customer:		Drawing No:	
		Serial No:	
Cust. Ref:		Drawn By:	EB
Factory Ref:		Checked By:	
Date:		Certified By:	

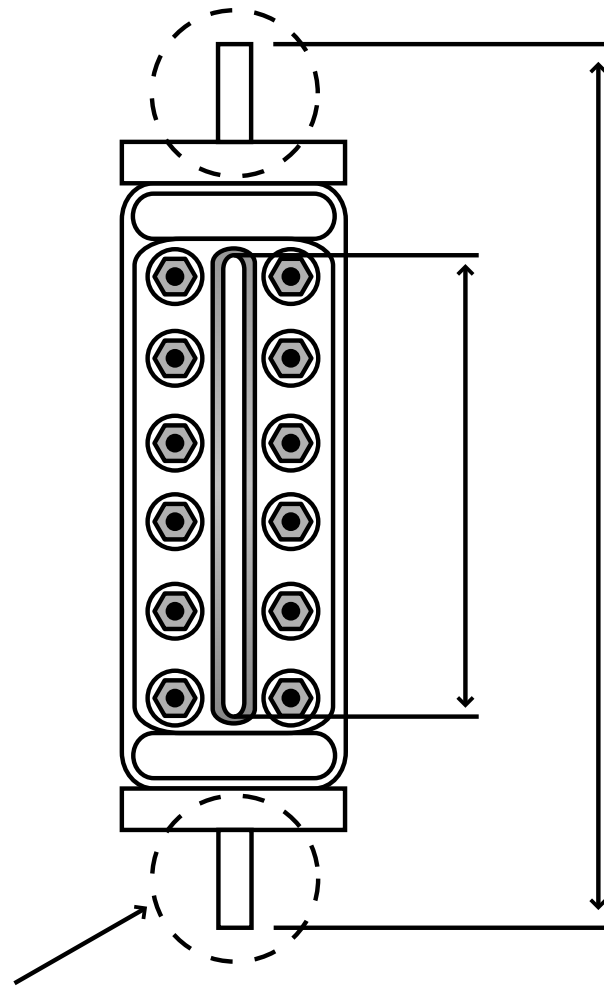

Model	Dim "A"
ST-1600-71	10.250
ST-1600-81	11.875
ST-1600-91	12.625
Dimensions in Inches	

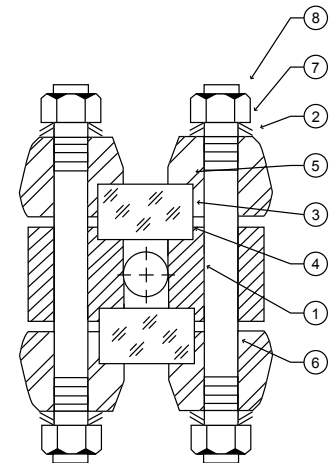

Gage Connection Options

