

# See-Level™ Illuminator

Gage lighting for Flat Glass Gages

## Installation Operation and Maintenance Manual

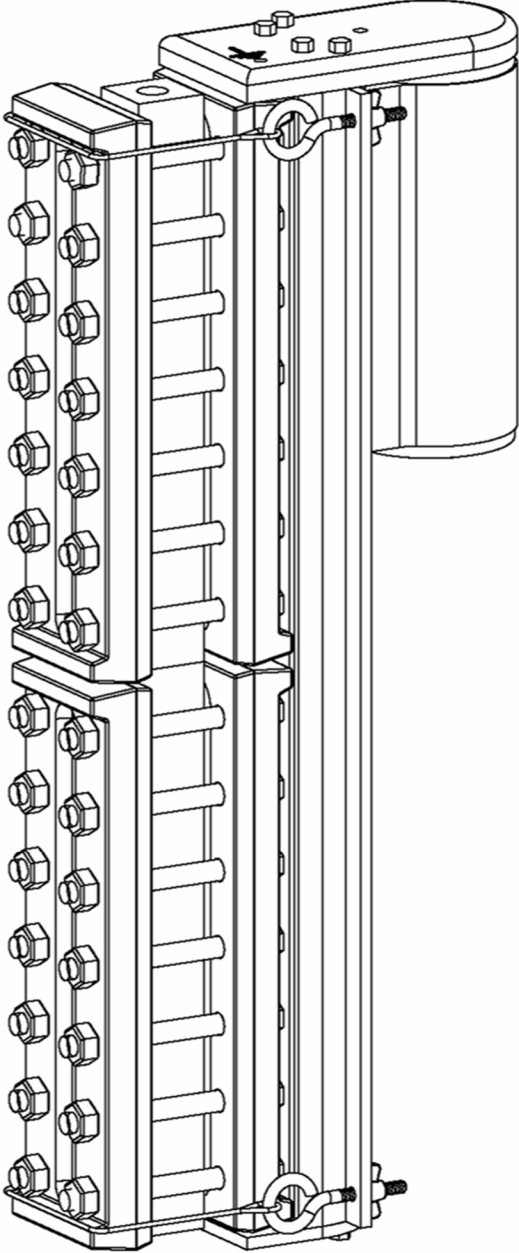

Quest-Tec Solutions  
[www.QTSLevel.com](http://www.QTSLevel.com)  
Houston, TX

# Table of Contents

1.0	About the Manual .....	1
2.0	Introduction .....	1
2.1	System Description.....	1
3.0	Available models.....	2
3.1	Approvals .....	2
3.2	AC Supply Voltage Ratings.....	2
3.3	Steam Application.....	3
4.0	Inspection & Storage.....	3
4.1	User Rating Inspection .....	3
5.0	Installation.....	3
5.1	Inspection and Cleaning of Glass .....	4
5.2	Installation of Unit to Gauge .....	4
5.3	Electrical Installation.....	4
6.0	Operation .....	5
7.0	Maintenance .....	5
7.1	Preventative Maintenance.....	6
7.2	Accessing Maintenance Items.....	6
7.3	Maintenance Procedures .....	6
8.0	Disassembly – Reassembly.....	8
8.1	Disassembly/Reassembly .....	8
9.0	Telephone Assistance.....	9
10.0	Parts listing .....	10

## **1.0 About the Manual**

This manual has been prepared as an aid and guide for personnel involved in installation or maintenance. All instructions must be read and understood thoroughly before attempting any installation, operation, or maintenance. Failure to follow any instruction could possibly result in a malfunction of the illuminator resulting in a loss of ability to read liquid level or failure of the liquid level gage resulting in leakage causing serious personal injury or electrical shock to personnel or property damage.

The manufacturer does not have any control over the manner in which its illuminators are handled, installed, or used. The manufacturer cannot and will not guarantee that an illuminator is suitable or compatible for the user's specific application.

Vessel fluids may be pressurized in the gage on which the illuminator is being attached. Fluids can unexpectedly exit vessel connections due to apparatus or material failure. Safety glasses should be worn when installing an illuminator. Failure to do so could result in serious physical injury to personnel.

## **2.0 Introduction**

The illuminators are designed to be readily installed to any style flat glass liquid level gage.

### **2.1 *System Description***

The illuminators are comprised of 4 basic components. Use the exploded parts view in Section 10.0 as additional reference material.

Illuminator body – a rigid, aluminum, protective structure that supports and houses the illuminating elements of the illuminator. The illuminator body can be mounted either side up to allow for clearance with existing plant structures.

Electronics housing – an explosion proof, water tight, aluminum, protective housing that contains power conversion and protective circuitry along with field wiring connections.

Power converting and barrier electronics – Protective circuitry capable of accepting a wide range of AC voltages and frequencies which provides 2 channels of IS power to the Lighting Electronics. This power is incapable of causing a spark and subsequent ignition.

Lighting Electronics – A conformal coated, weatherproof, and replaceable PCB containing the Light Emitting Diodes.

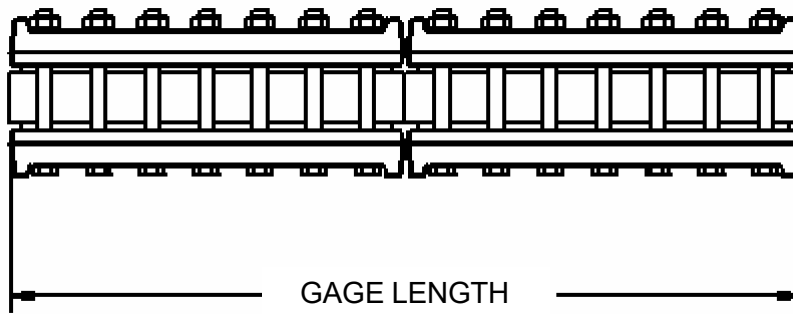

Figure 1: Overall Gauge Length

### 3.0 Available models

Flat glass gage illuminators are available in custom lengths to fit any length of visible glass. When ordering illuminators for currently installed gauges the overall gauge length, manufacturer, style, and the size of each section must be specified (figure 1).

### 3.1 Approvals

Units utilize explosion proof and intrinsic safety protection.

NEMA 4X enclosure  
Class 1, Division 1, Group B C D  
Operating Temperature T5  
Voc: 8.61 VDC  
It: 1.511 A  
Ambient temp: -40..150F,-  
40..60C



LISTING # E112404

**Complies With**  
UL 60950-1  
UL 913  
UL 1203  
CSA C22.2 No.30  
CSA C22.2 No.157  
CSA C22.2 No.60950-1

### 3.2 AC Supply Voltage Ratings

The acceptable field wiring input is 50/60 Hz 115 ( $\pm 10\%$ ) VAC or 50/60 Hz 230 ( $\pm 10\%$ ) VAC, for all standard models, as tagged.

NEVER exceed these design ratings or application data. Exceeding design ratings or application data may result in unit failure or the creation of excessive heat and potential ignition of volatile fluids or gasses, causing serious injury, death, and/or property damage.

### **3.3 Steam Application**

Due to the high surface temperatures possible on steam gauges and the thermal sensitivity of electronics, care must be taken to ensure the heat transfer to the illuminator is low enough as to not significantly raise the surface temperature of the explosion proof housing.

## **4.0 Inspection & Storage**

Upon receipt of an illuminator, check all components carefully for damage incurred in shipping. If damage is evident or suspected, do not attempt installation, notify carrier immediately and request damage inspection. Refer to the exploded view drawing in Section 10.0 to inventory parts.

Store illuminator indoors in a clean and dry location until ready for installation.

### **4.1 User Rating Inspection**

The user should confirm that:

1. The illuminator size, rating and model number stamped on nameplate conforms to the description on the user's purchase order.
2. Confirm the Power Supply configuration.
3. The operating conditions described in the purchase order agree with the actual operating conditions at the installation site.
4. The actual operating conditions at the installation site are within the applications data in this manual.
5. The materials of construction of the illuminator are compatible with the surrounding atmosphere in the specific application.

## **5.0 Installation**

It is the user's responsibility to assure that knowledgeable installation personnel plan and carry out the installation in a safe manner. The following procedures are some of the guidelines that should be employed.

## 5.1 Inspection and Cleaning of Glass

The manufacturer recommends that prior to installation of an illuminator to a gage, that the gage glass be cleaned and inspected per instructions as follows:

1. Clean glass within vision slot using a non-abrasive household cleaner. DO NOT use wire brush, metal scraper or any device which could scratch the glass.
2. Inspect the surface of the glass for any signs of clouding, etching, scratching or physical damage such as bruises, checks or erosion that penetrates the outer surface of the glass. Shining a light at approximately at a 45° angle will aid in detecting some of these conditions. Light will glisten more brightly on glass imperfections than the surrounding glass when reflecting light. Detection of any such problem areas or surface wear is sufficient evidence of damage. Do not proceed with installation with damaged glass. See appropriate Installation, Operation and Maintenance manual and replace glass.

## 5.2 Installation of Unit to Gauge

Become familiar with the illuminator components before proceeding with installation. Refer to the exploded parts drawing in Section 10.0 when performing the following installation instructions.

1. Mount illuminator to flat glass gage as shown in figure 2.
2. Wrap top lanyard around front of gauge above the top bolts and hook onto 2 eyehooks.
3. Tighten top lanyard wing nuts until lanyard is taught.
4. Wrap bottom lanyard around front of gauge under the bottom bolts and hook onto 2 eyehooks.
5. Tighten bottom wing nuts until lanyard is taught.
6. Connect external ground strap to marked area on Pocket cover plate (8)

For removal, complete steps in reverse.

## 5.3 Electrical Installation

*DO NOT proceed with electrical installation unless the illuminator has been mounted to the gage according to instructions in Section 5.2 and is externally grounded. Only qualified electricians who have read and understood local and national electrical code should connect the*

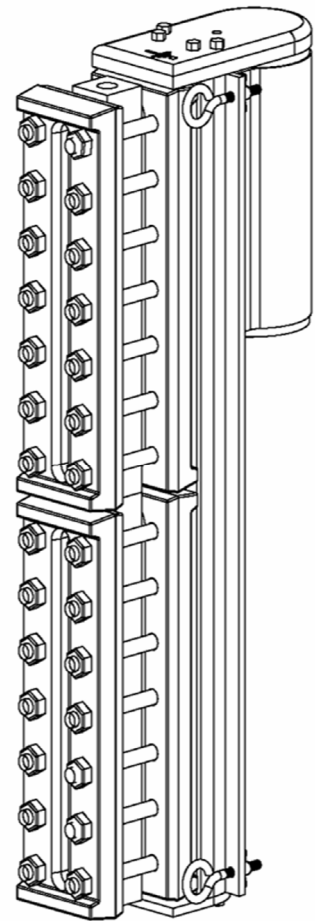

Figure 2: Illuminator on Gage

*illuminator to an electrical source. Failure to follow any of the above instructions can result in damage to the illuminator, gage, personnel and/or property.*

The electrical installation should be performed by a qualified electrician and comply with applicable codes (U.S. – refer to National Electric Code NFPA current edition; Canada – refer to Canadian Electrical Code CSA C22) or other regulations as applicable. The conduit must be run in such a manner that it is not supported by or does not serve as a support for the illuminator.

A conduit seal-off **must** be installed within two inches of conduit entry port for Group B locations or 18 inches for Group C & D locations. Resistance between intrinsically safe ground terminal and earth ground must be less than 1 Ohm. Installation must be in accordance with NEC (ANSI/NFPA-70).

**Note:** Once the field wiring conduit is attached to the Electrical Housing check and ensure the cap on housing is secured.

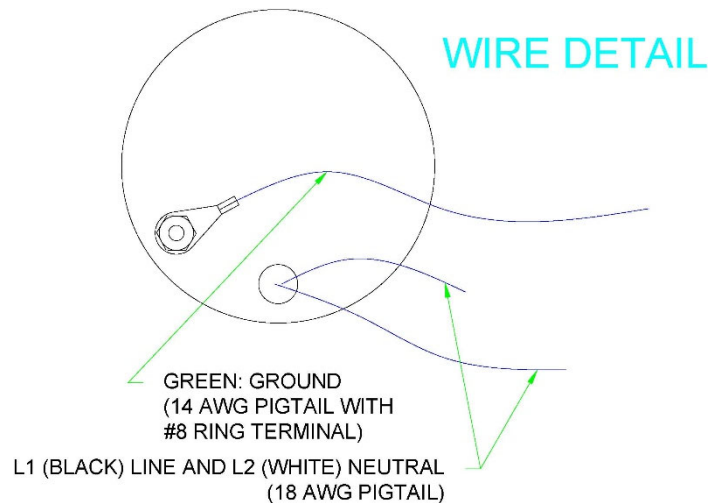

## 6.0 Operation

Check that all installation procedures have been completed. *Use only qualified, experienced personnel who are familiar with illuminators and thoroughly understand the implications of the tables and all the instructions.* Check that illuminator has sufficient light output over the entire visible length of the liquid level gage.

## 7.0 Maintenance

*Use only qualified, experienced personnel who are familiar with illuminators and thoroughly understand the implications of the tables and all the instructions.*

DO NOT proceed with any maintenance unless:

- 1) The gage assembly has been relieved of all pressure or vacuum, has been allowed to reach ambient temperature and has been drained or purged of all fluids and,
- 2) The electrical power has been turned off. Failure to do so can cause personal injury, death and/or property damage.

The user must create maintenance schedules, safety manuals, and inspection details for each specific installation of an illuminator.

During plant maintenance procedures that require sand blasting insure illuminator is removed from the sand blasting area.

## **7.1 Preventative Maintenance**

On all installations the following items should be regularly evaluated by the user:

1. Mounting hardware, for signs of loosening.
2. Electrical Housing, caps/conduit for tightness

The user must determine upon evaluation of his or her own operating experience an appropriate maintenance schedule necessary for his or her specific application. Realistic maintenance schedules can only be determined with full knowledge of the services and application situation involved.

## **7.2 Accessing Maintenance Items**

The Illuminator requires no maintenance other than cleaning. In the event of component failure the electronics housing complete with Power converting and barrier electronics and the lighting electronics are line replaceable units.

## **7.3 Maintenance Procedures**

Refer to section 10 during maintenance.

**To replace the supply fuse inside the electronics housing.**

1. Remove illuminator from gage (refer to section 5.2).
2. Remove four self-tapping screws (7) on end with external ground.
3. Remove pocket cover plate (8).
4. Remove supply explosion proof cap (4)
5. Disconnect supply wires and IS ground under supply explosion proof cap (4)
6. Loosen locking bolts (19) and remove electronics housing (11) from illuminator body (5).



7. Unscrew and remove carrier explosion proof cap (6) and all attached items.
8. Remove and replace supply fuse located beside transformer on electronics board (3).
9. Reinstall carrier explosion proof cap (6) and associated pieces into electronics housing (11).
10. Reinstall LED illuminating element(s) (9) into illuminator body (5).
11. Slide electronics housing (11) onto illuminator body (5).
12. Lock electronics housing into place with 2 locking bolts (19).
13. Reconnect supply wires and IS ground under supply explosion proof cap (4).
14. Install supply explosion proof cap (4).
15. Reinstall pocket cover plate (8).
16. Reinstall four self-tapping screws (7).
17. Reinstall illuminator onto gage (refer to section 5.2)

**To replace the lighting electronics:**

1. Remove illuminator from gage (refer to section 5.2).
2. Remove four self-tapping screws (7) on end with external ground.
3. Remove pocket cover plate (8).

**Note:**

When clipping wires be sure to leave enough wire for future splices.

4. Disconnect/clip wiring between electronics housing and illuminating elements.

**Note:**

Keep spacers in order for reuse in reassembly.

5. Remove illuminating element(s) (9).
6. Install new illuminating element(s) and reusable spacers if present.

**Note:**

Connection type must be environmentally sealed.  
Use only approved illuminating elements from the manufacturer.

7. Connect wire of new illuminating element to existing wires from the power supply.
8. Reinstall cover plate (8)
9. Reinstall four self-tapping screws (7)
10. Reinstall illuminator to gage (refer to section 5.2)

**To replace the electronics housing internals:**

1. Remove illuminator from gage (refer to section 5.2)
2. Remove four self-tapping screws (7) on end with external ground.
3. Remove pocket cover plate (8)
4. Disconnect/clip wiring between electronics housing and illuminating elements.
5. Remove supply explosion proof cap (4)
6. Disconnect supply wires under supply explosion proof cap (4)
7. Unscrew and remove carrier explosion proof cap (6) and all attached items.
8. Install new carrier explosion proof cap (6) and all attached items

**Note:**

Connection type must be environmentally sealed.

9. Connect wiring of new electronics housing to existing wiring of illuminating elements.
10. Replace cover plate (8)
11. Replace 4 self-tapping screws (7)
12. Connect supply to new electronics housing.
13. Reinstall supply explosion proof cap (4)

## **8.0 Disassembly – Reassembly**

*Use only qualified, experienced personnel who are familiar with illuminators and thoroughly understand the implications of the tables and all the instructions. DO NOT proceed with any maintenance unless:*

- 1) The gage assembly has been relieved of all pressure or vacuum, has been allowed to reach ambient temperature and has been drained or purged of all fluids and
- 2) The electrical power has been turned off. Failure to do so can cause serious personal injury, death and/or property damage.

### **8.1 Disassembly/Reassembly**

Line replaceable component replacement is covered in section 7. Further disassembly, reassembly, repair, or alteration may void certification and should not be attempted on site.

## 9.0 Telephone Assistance

If you are having difficulty with your illuminator, notify your local Quest-Tec distributor. You may also contact the factory direct at (281)-240-0440. So that we may assist you more effectively, please have as much of the following information as possible when you call:

Model No.:

Name of the company from whom you purchased your illuminator:

Invoice # and date:

Operating temperatures:

A brief description of the problem:

Troubleshooting procedures that failed:

If attempts to solve your problem fail, you may be requested to return your illuminator to the factory for intensive testing. You must obtain a Return Merchandise Authorization (RMA) number from Quest-Tec prior to returning anything. Failure to do so will result in the unit being returned to you, without being tested, freight collect. To obtain a RMA number, the following information (in addition to that above) is needed:

Reason for return

Person to contact at your company

“Ship to” address

Quest-Tec Solutions recommends that you return the entire illuminator for testing. There is a minimum charge of \$75.00 for evaluation for non-warranty units and a purchase order for this amount must be received before evaluation proceeds. You will be contacted before any repairs are initiated should the cost exceed the minimum charge. If you return a unit that is covered by the warranty, but is not defective, the minimum charge will apply.

## 10.0 Parts listing

ITEM	QUANTITY
1. Shallow cover plate	(1)
2. Carrier pegs	(2)
3. Barrier board	(1)
4. Supply EXP cap(w/o-ring)	(1)
5. LED housing	(1)
6. Carrier EXP cap(w/o-ring)	(1)
7. Self-tapping screws	(8)
8. Pocket cover plate	(1)
9. LED board	(1-4)
10. Protective glass	(1-4)
11. EXP case body	(1)
12. Eyebolts/hooks	(4)
13. Wing nuts	(4)
14. #8 cap screws	(6)
15. Teflon insulating disc	(1)
16. Lanyard	(2)
17. Identification plate	(1)
18. Rivets	(2)
19. Locking bolts	(2)

