

# CERTIFICATE OF REGISTRATION

This is to certify that the management system of:

## Quest-Tec Solutions, Inc.

Main Site: 13960 South Wayside Drive  
Houston  
Texas 77048  
United States

has been registered by Intertek as conforming to the requirements of:

## ISO 9001:2015

The management system is applicable to:

The development, manufacturing and selling of Level Indicating Components used in the petrochemical and power industries.

**Certificate Number:**

CERT-0146285

**Initial Certification Date:**

07 May 2019

**Date of Certification Decision:**

22 April 2025

**Issuing Date:**

22 April 2025

**Valid Until:**

05 May 2028



intertek

**Rathin Grover**

President, Business Assurance

Intertek Testing Services NA,  
Inc. dba Intertek,  
4700 Broadmoor SE Suite 200 Kentwood,  
Michigan 49512, United States



### TYPE 3A-S & 3A-U

Heavy Duty OS&Y

PRESSURE - TEMPERATURE RATINGS (PSIG @ ° F)			
Temp	ASME B16.34 Class 900 Rating, SA-105, SA-350 LG2	ASME B16.34 Class 900 Rating, SA-182 F316 SS	Manufacturer's Rating
100° F	2220 psi	2160 psi	4000 psi
200° F	2035 psi	1860 psi	3730 psi
300° F	1965 psi	1680 psi	3470 psi
400° F	1900 psi	1540 psi	3200 psi
500° F	1810 psi	1435 psi	2950 psi
600° F	1705 psi	1355 psi	2700 psi
700° F	1590 psi	1305 psi	2430 psi

PARTS			
ITEM#	NAME	STANDARD	316 SS WETTED PARTS
		MATERIAL	MATERIAL
1	BODY	FORGED CARBON STEEL	316 SS
2	UNION NUT	CARBON STEEL	316 SS
3	BALL	440 SS	316 SS
6	STEM	416 SS	316 SS
7	PACKING WASHER	17-4 PH SS	316 SS
8	PACKING RING	TEFLON	TEFLON
9	PACKING FOLLOWER	316 SS	316 SS
11	HANDWHEEL	IRON	IRON
12	NAMEPLATE	304 SS	304 SS
13	HANDWHEEL NUT (LEFT HAND THREADS)	316 SS	316 SS
14	FEMALE CONNECTOR	CARBON STEEL	316 SS
15	SEAT	416 SS	316 SS
17	YOKE GASKET	304 SS / GRAPHITE	316 SS / GRAPHITE
18	YOKE	FORGED CARBON STEEL	316 SS
19	YOKE SCREW	SA-193 B7	SA-193 B7
20	PRESSURE BAR	CARBON STEEL	CARBON STEEL
21	PRESSURE BAR STUD	SA-193 B7	SA-193 B7
22	PRESSURE BAR NUT	SA-194 2H	SA-194 2H
23	INNER THRUST WASHER	17-4 PH SS	17-4 PH SS
24	HANDWHEEL SCREW	SIL BRZ	SIL BRZ
25	OUTER THRUST WASHER	17-4 PH SS	17-4 PH SS
26	INTERNAL TOOTH LOCK WASHER	410 SS	410 SS

The Type 3A valve replaces the obsolete Type 3 valve. This is due to a re-design of the yoke and packing compression sub-assembly. All fitting dimensions are identical to the Type 3. Type 3 valve parts are still available. Type 3 Valves sets may be upgraded to Type 3A by replacing the yoke sub-assembly.

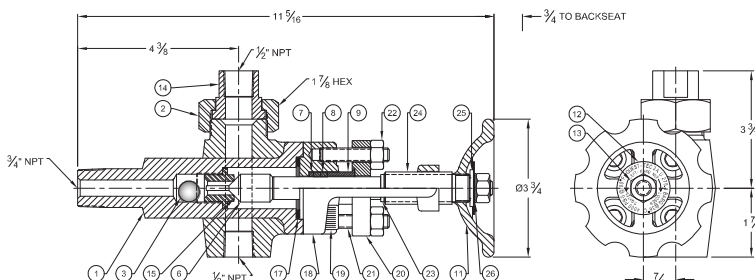
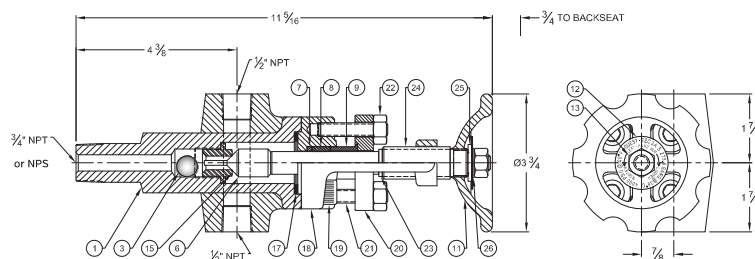

Glass-Trac Type 3A valves are the model to select for the most for the most rigorous service. These gage valves have the following standard features:

- Outside Screw & Yoke – Stem threads are external and do not contact the process
- Reciprocating Stem – The stem rises and falls against the seat without twisting through the packing
- Back Seating Stem – Pressure on the packing is relieved when the valves are full open
- Automatic Ball Check – In the event of gage glass failure, vessel contents will be contained automatically
- Full ASME 16.34 compliance to 900# Class
- Offset Flow Path – This permits cleaning a top and bottom connected gage through the vent or drain port
- Solid Shank Vessel Connection – Typically flanged to meet user's requirements

Type 3A gage valves are available in four basic gage connection configurations:

- Type 3A-S – With a rigid, 1/2" or 3/4", NPT or SW connection to the Level Gage
- Type 3A-U – With a metal-to-metal union connection to the Level Gage
- Type 3A-G – With a gasketed union connection to the level gage
- Type 3A-T – Tubular gage connection to the level gage

### Low Emissions Valve Type 3A-S-LE, 3A-U-LE, 3A-G-LE, 3A-T-LE

The type 3A valve can be supplied with a package that has been certified to the demanding API 624 Low Emissions Type Testing of Rising Stem Valves Equipped with Graphite Packing for Fugitive Emissions standard.

#### 3A-S

- Certified to API 624 Low Emissions Standard, 1st Edition
- Tedit Style 2236 Emissions Packing certified to API 622
- USA forged valve body

#### 3A-U

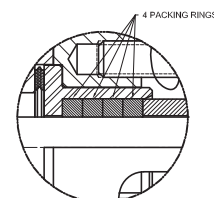

Low Emissions Packing



# CERTIFICATE OF AUTHORIZATION

The named company is authorized by the American Society of Mechanical Engineers (ASME) for the scope of activity shown below in accordance with the applicable rules of the ASME Boiler and Pressure Vessel Code. The use of the certification mark and the authority granted by this Certificate of Authorization are subject to the provisions of the agreement set forth in the application. Any construction stamped with this certification mark shall have been built strictly in accordance with the provisions of the ASME Boiler and Pressure Vessel Code.

COMPANY:

**Quest-Tec Solutions, Inc.  
13960 South Wayside Drive  
Houston, Texas 77048**

SCOPE:

**Manufacture and assembly of power boilers at the above location only**

AUTHORIZED: **May 11, 2018**

EXPIRES: **May 11, 2021**

CERTIFICATE NUMBER: **51,422**

  
Board Chair, Conformity Assessment

  
Managing Director, Conformity Assessment



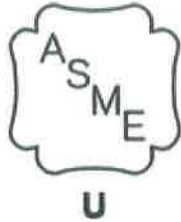

# CERTIFICATE OF AUTHORIZATION

The named company is authorized by the American Society of Mechanical Engineers (ASME) for the scope of activity shown below in accordance with the applicable rules of the ASME Boiler and Pressure Vessel Code. The use of the certification mark and the authority granted by this Certificate of Authorization are subject to the provisions of the agreement set forth in the application. Any construction stamped with this certification mark shall have been built strictly in accordance with the provisions of the ASME Boiler and Pressure Vessel Code.

COMPANY:

**Quest-Tec Solutions, Inc.  
13960 South Wayside Drive  
Houston, Texas 77048**

SCOPE:

**Manufacture of pressure vessels at the above location only**

AUTHORIZED: **May 11, 2018**

EXPIRES: **May 11, 2021**

CERTIFICATE NUMBER: **55,649**

Handwritten signature of Richard R. Stevenson in black ink.

Board Chair, Conformity Assessment

Handwritten signature of Joseph J. Lovato in black ink.

Managing Director, Conformity Assessment



**THE NATIONAL BOARD  
OF  
BOILER & PRESSURE VESSEL INSPECTORS**

***Certificate of Authorization***



*This is to certify that*

**Quest-Tec Solutions, Inc.  
13960 South Wayside Drive  
Houston, Texas 77048  
United States**

**Acceptable Abbreviation: QTS**

*is authorized to use the R Symbol in accordance with the provisions of the National Board Inspection Code and NB-415, Accreditation of "R" Repair Organizations.*

All activities within the scope of this Authorization shall be controlled by the above location.

The scope of this Authorization is limited to:

Metallic  
Repairs and Alterations  
At The  
Shop Location



Certification Number: 9787

Issue Date: May 14, 2018

Expiration Date: May 14, 2021

Executive Director

## FLUSH RING

USED TO CLEAN & FLUSH THE DP TRANSMITTER DIAPHRAGM SEAL  
INSTALLED BETWEEN THE DIAPHRAGM SEAL AND PROCESS CONNECTION

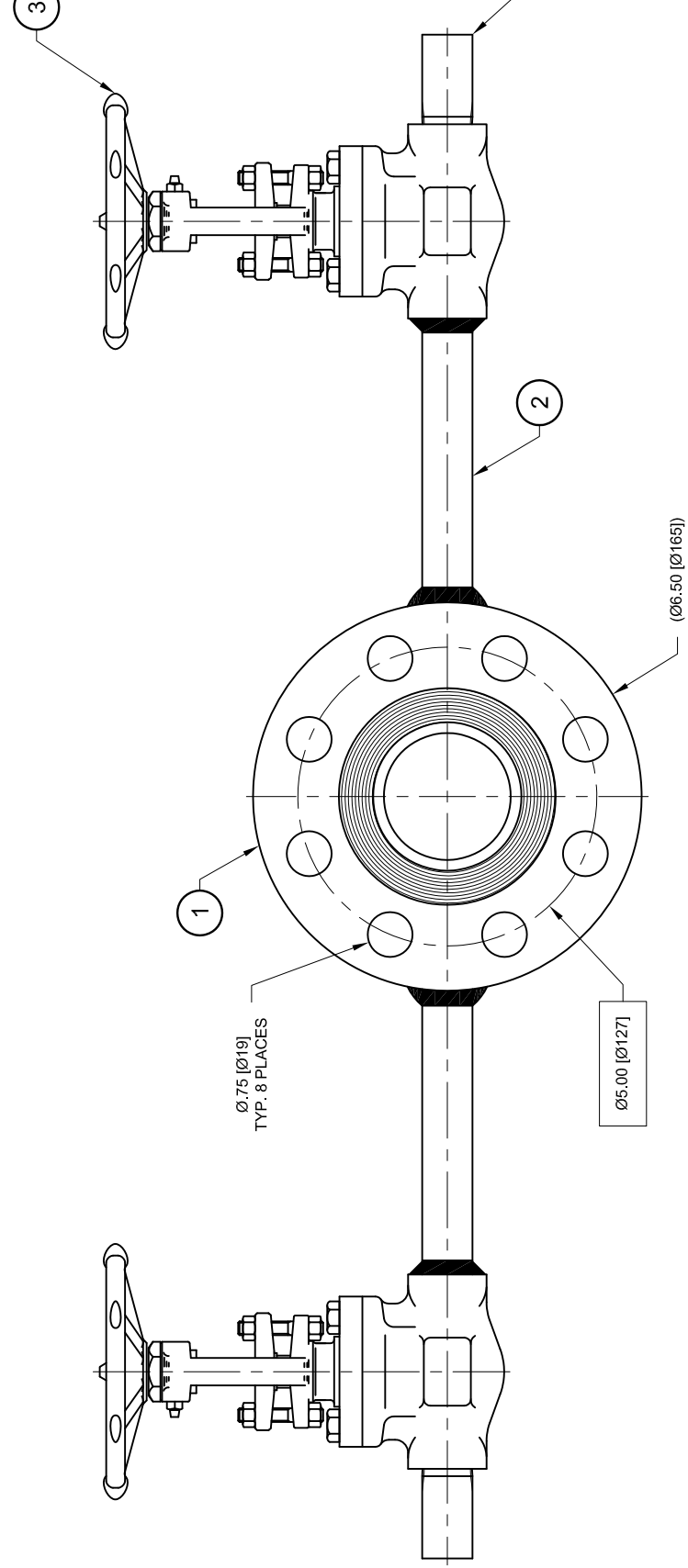
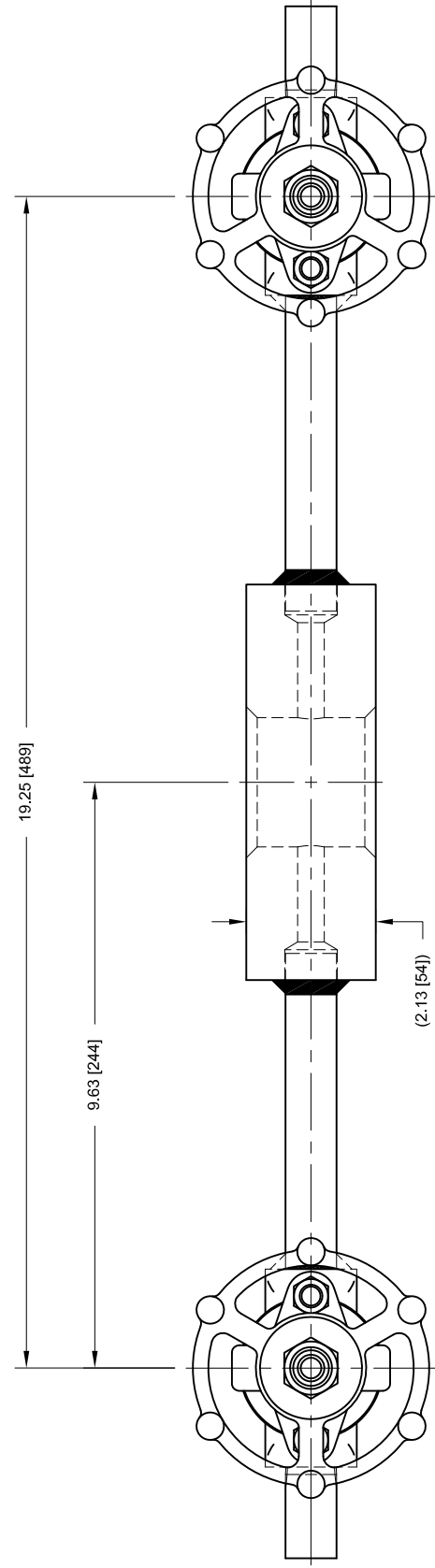

## FLUSH RING

USED TO CLEAN & FLUSH THE DP TRANSMITTER DIAPHRAGM SEAL  
INSTALLED BETWEEN THE DIAPHRAGM SEAL AND PROCESS CONNECTION

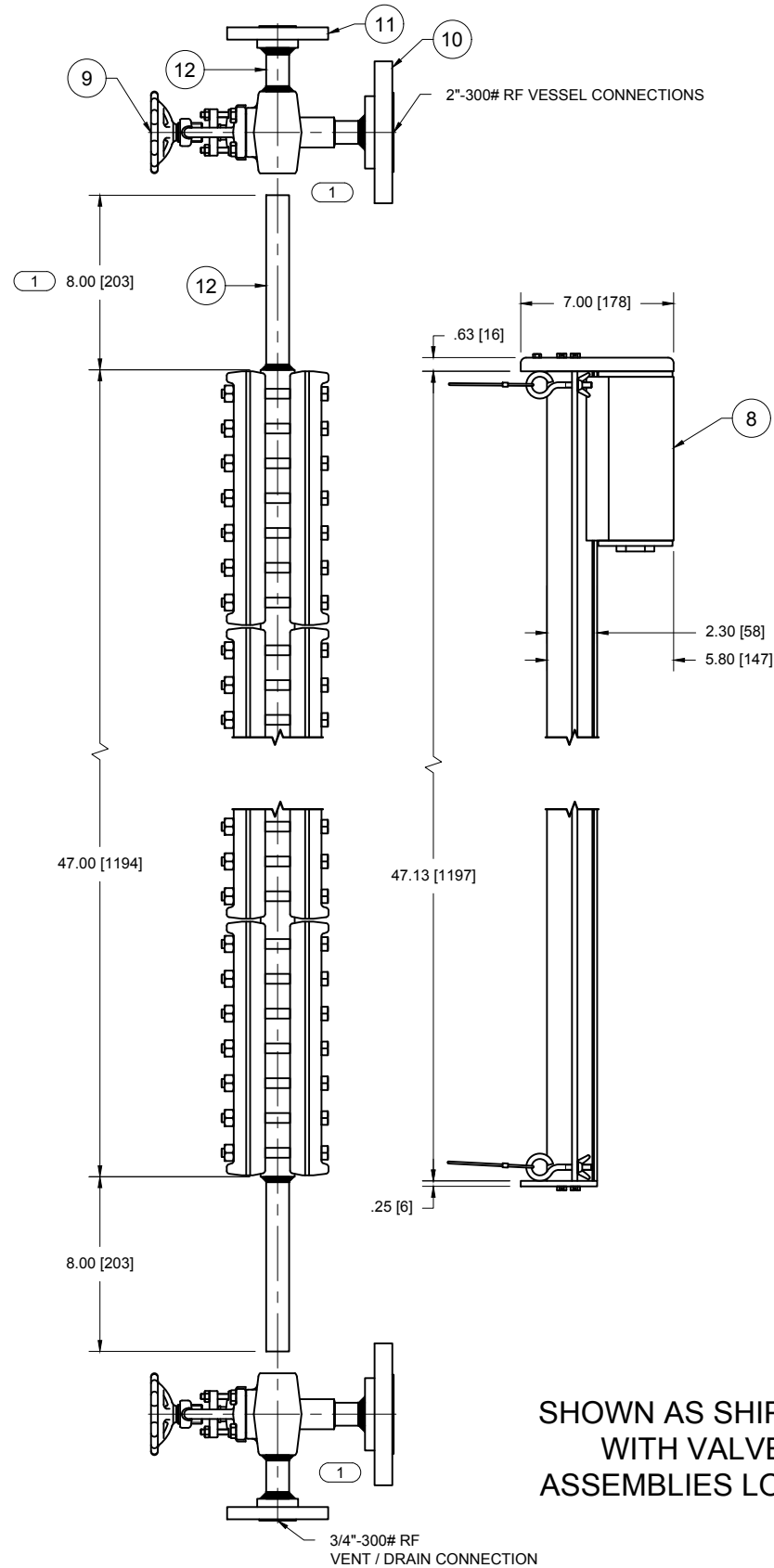
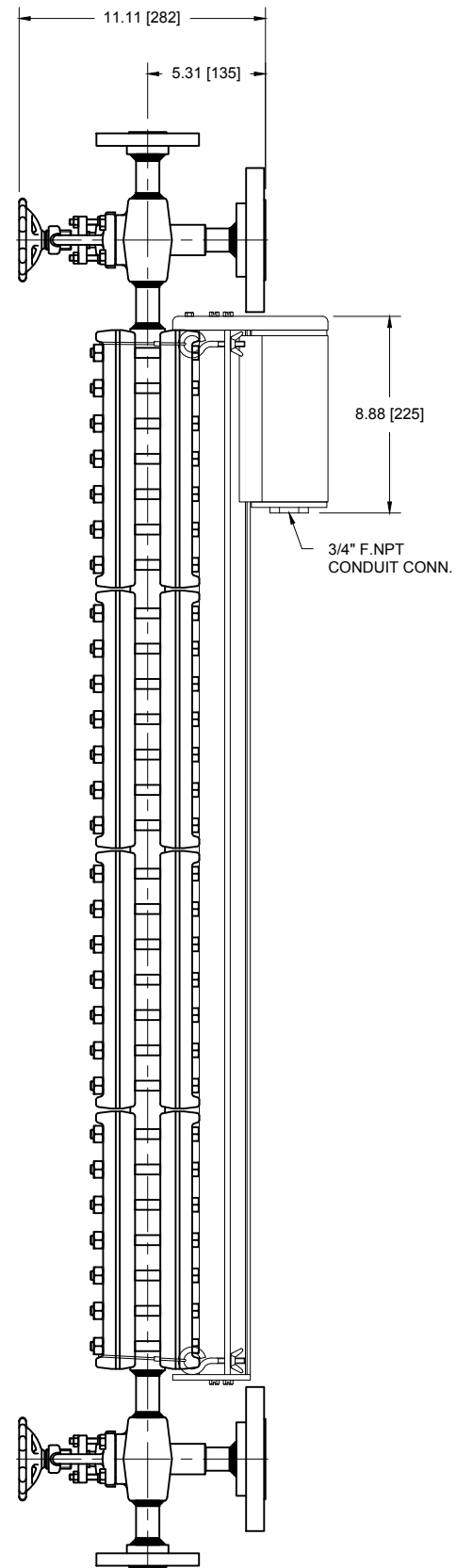
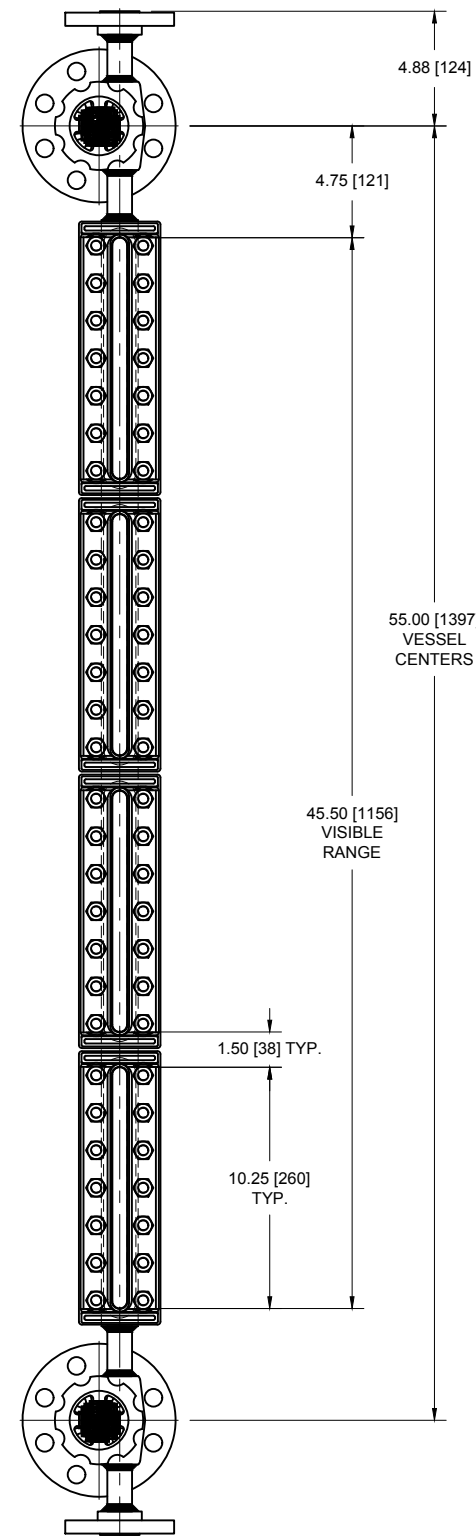

SHOWN AS SHIPPED  
WITH VALVE  
ASSEMBLIES LOOSE

BILL OF MATERIALS		
ITEM#	DESCRIPTION	MATERIAL
1	CHAMBER	CARBON STEEL
2	COVER	CARBON STEEL
3	GLASS	TEMPERED BOROSILICATE
4	GASKET	GRAFOIL
5	CUSHION	GARLOCK IFG-5500
6	BOLT	SA-193 B7
7	NUT	SA-194 2H
8	SLI-74-115AC-WC	ANODIZED ALUMINUM
9	TYPE 7-S VALVE ASSEMBLY	CS BODY / 316 SS TRIM / GRAFOIL PACKING
10	2" x 3/4"-300# RFSW SCH 160 FLANGE	CARBON STEEL
11	3/4"-300# RFSW SCH 160 FLANGE	CARBON STEEL
12	3/4" SCH 160 PIPE NIPPLE	CARBON STEEL

NOTE:  
POST WELD HEAT TREAT ALL CONNECTIONS.

REV	DATE	DESCRIPTION	DRN	APPD
1	7/7/16	LOWER VALVE FLANGES TO BE ASSEMBLED AND REMOVE WELD FROM UPPER VALVE TO GAGE CONNECTION.	PCD	JLR

UNLESS OTHERWISE NOTED ALL DIMENSIONS IN INCHES [mm]

**CUSTOMER:**  
**CUST. PO#:**  
**FACT. REF.:** 30559 / 026523  
**QUOTE#:**  
**GAGE RATING:**  
 740 psig @ 100° F / 588 psig @ 550° F  
**TESTING & DOCUMENTATION:**  
 1) HYDROSTATIC TEST AT 1110 psig.  
 2) MATERIAL TEST REPORTS.

**APPROVAL DRAWING:**  
 APPROVED AS IS TO MFG.  
 APPROVED AS NOTED TO MFG.  
 NOT APPROVED-RESUBMIT BEFORE MFG.  
 SIGNED BY: \_\_\_\_\_ DATE: \_\_\_\_\_  
 DRAWING TO BE RETURNED TO QTS BY: \_\_\_\_\_ TO AVOID DELAY.

THIS DRAWING IN DESIGN AND DETAIL IS OUR PROPERTY AND MUST NOT BE USED EXCEPT IN CONNECTION WITH OUR WORK. IT SHALL NOT BE REPRODUCED AND SHALL BE RETURNED TO US ON DEMAND. ALL RIGHTS ARE RESERVED.  
 SIMETRIC  
 THIRD ANGLE PROJECTION

**QTS**  
 Quest-Tec Solutions  
 The New Standard of Level

13980 SOUTH WAYSIDE DR.  
 HOUSTON, TEXAS 77048  
 OFFICE (281)240-0440  
 FAX (281)240-2440  
 WWW.QTSLlevel.com

TITLE: 74TM LEVEL GAGE & 7-S VALVES  
 PER JOB# 026523 MARATHON PETROLEUM CO. LP

DRN	PCD	DATE	6/16/16	SIZE	DRAWING #	REV
CHKD	RET	DATE	6/16/16	B	1-9-30559-1	1
APPD	RET	DATE	6/16/16	SCALE	N.T.S.	SHEET 1 OF 1

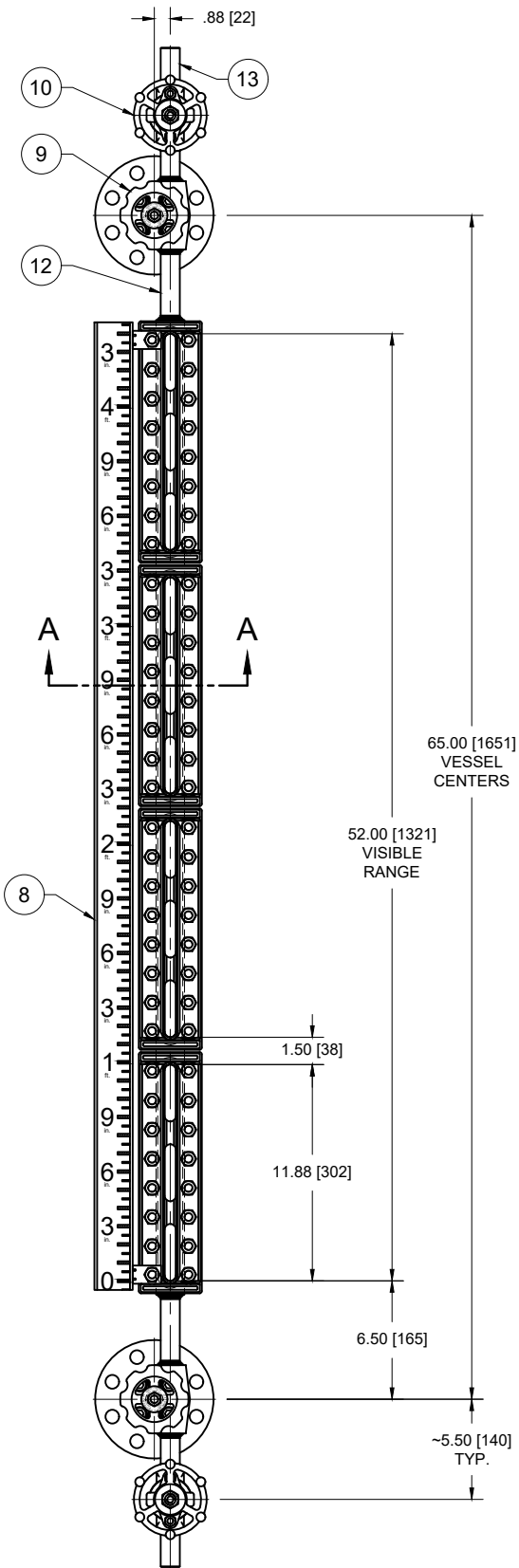

BILL OF MATERIALS		
ITEM#	DESCRIPTION	MATERIAL
1	CHAMBER	CARBON STEEL
2	COVER	CARBON STEEL
3	GLASS	TEMPERED BOROSILICATE
4	GASKET	GRAFOIL
5	CUSHION	GARLOCK IFG-5500
6	BOLT	SA-193 B7M
7	NUT	SA-194 2HM
8	SCALE (in / ft)	304 SS / ANODIZED ALUMINUM
9	3A-S-LE VALVE ASSEMBLY	CS BODY / 316 SS TRIM / BRAIDED FLEXIBLE GRAPHITE
10	3/4" CL800 SW x NPT GATE VALVE	CS BODY / API 12 TRIM (NACE)
11	2" x 3/4"-300# RFSW SCH 160 FLANGE	CARBON STEEL
12	3/4" SCH 160 PIPE NIPPLE	CARBON STEEL
13	3/4" NPT ROUND HEAD PLUG	CARBON STEEL

- NOTES:
- 1) GAGE VALVES ARE LOW EMISSIONS API 624.
  - 2) GAGE VALVES INCLUDE BALL CHECK.
  - 3) GATE VALVE ARE LOW EMISSIONS API 602.
  - 4) ASSEMBLY TO INCLUDE Ø3/8" STEAM TRACING OUTSIDE OF BOLTING.
  - 5) ASSEMBLY TO INCLUDE INSULATION JACKET.

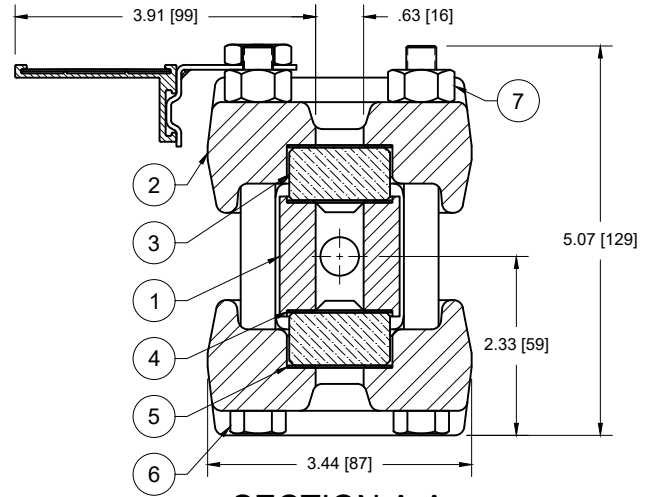

SECTION A-A

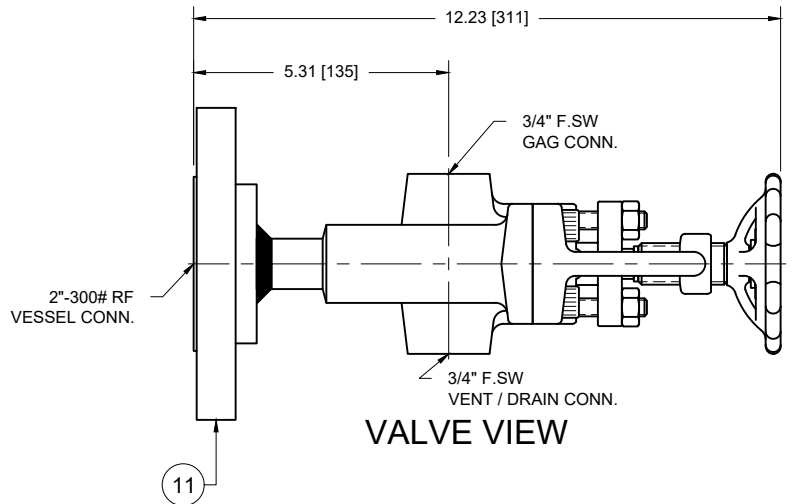

VALVE VIEW

**CUSTOMER:**  
**CUST. PO#:**  
**FACT.REF.:** 37717 / 032673  
**TAG#:**  
**RATING:** 740 PSI @ 100° F / 570 PSI @ 600° F  
**TESTING & DOCUMENTATION:**  
 1) HYDROSTATIC TEST AT 1110 PSIG.  
 2) MATERIAL TEST REPORTS.  
 3) CERT. OF COMPLIANCE TO NACE MR0103.  
 4) PWHT AT 1175 ±25° F FOR 2 HOURS.  
 5) BRINELL HARDNESS TEST 100%.  
 6) LEVEL II VISUAL TEST 100%.

**APPROVAL DRAWING:**

APPROVED AS IS TO MFG.  
 APPROVED AS NOTED TO MFG.  
 NOT APPROVED-RESUBMIT BEFORE MFG.

SIGNED BY: \_\_\_\_\_  
 DATE: \_\_\_\_\_

THIS DRAWING IN DESIGN AND DETAIL IS OUR PROPERTY AND MUST NOT BE USED EXCEPT IN CONNECTION WITH OUR WORK. IT SHALL NOT BE REPRODUCED AND SHALL BE RETURNED TO US ON DEMAND. ALL RIGHTS ARE RESERVED.

SI METRIC  
 THIRD ANGLE PROJECTION

UNLESS OTHERWISE NOTED ALL DIMENSIONS IN INCHES [mm]

**QTS**  
 Quest-Tec Solutions  
 The New Standard of Level

13960 SOUTH WAYSIDE DR.  
 HOUSTON, TEXAS 77048  
 OFFICE (281)240-0440  
 FAX (281)240-2440  
 WWW.QTSLlevel.com

QR CODE

TITLE: 84TH LEVEL GAGE w/ 3A-S-LE VALVE ASSEMBLY

PER JOB# 032673 MARATHON PETROLEUM CO. LP

DRN	PCD	DATE	9/23/19	SIZE	DRAWING #	REV
CHKD	RET	DATE	9/24/19	A	1-9-37717-1	0
APPD	RET	DATE	9/24/19	SCALE	N.T.S.	SHEET 1 OF 1

BILL OF MATERIAL

ITEM	DESCRIPTION	MATERIAL	ITEM
1	CHAMBER	SA-696 GR C	1
2	COVER	SA-105	8
3	GLASS	TEMPERED ALUMINOSILICATE	8
4	GASKET	GRAFOIL GHR	8
5	SHIELD	MICA, HQ .009"-.012"	8
6	CUSHION	GRAFOIL GHR	8
7	BOLT	SA193 GR B7	64
8	NUT	SA194 GR 2HM	64
9	84TM LEVEL GAGE ASSEMBLY	REF. ITEMS 1 THRU 8	1
10	SLI-84A LED ILLUMINATOR (SECTION VIEW ONLY)	SEE DWG. 1-9-37194-2	1
11	2 NPS S/80 PIPE NIPPLE, BBE	SEAMLESS SA-106B/C	3
12	2 NPS 300# RF WN S/80 FLANGE	SA-105	2
13	2 NPS S/80 BW x 3/4 SW END CAP	SA-105	2
14	2 NPS S/80 BW TEE	SA-234 WPB	2
15	3/4 NPS 3000# SOCKOLET	SA-105	2
16	3/4 NPS S/160 PIPE NIPPLE, PBE	SEAMLESS SA-106B/C	8
17	3/4 NPS S/160 PIPE NIPPLE, TBE	SEAMLESS SA-106B/C	2
18	3/4 NPT ROUND HEAD PLUG	SA-105	4
19	TYPE 3A-U B16.34 900# CLASS GAGE VALVE ASS'Y	SA-105 BODY/316SS TRIM/GRAF PKG	2
20	3/4 NPS SW x NPT CLASS 800 BB GATE VALVE	SA-105/API TRIM #8	4
21	3/4 NPS SW x SW CLASS 800 BB GATE VALVE	SA-105/API TRIM #8	2
22	3/4 NPS 300# RF SW S/80 FLANGE	SA-105	4
23	3/4 NPS 300# SPIRAL WOUND GASKET	316SS/GRAFOIL	2
24	5/8"-11 HEAVY HEX NUT	SA194 GR 2H	16
25	5/8"-11 x 3" L FULL THREAD STUD	SA193 GR B7	8

CUSTOMER:	FCX PERFORMANCE
CUST. P.O.:	4771713
FACTORY REF.:	37194/032219
LOCATION:	MARATHON GBR
TAG NO.:	CF-LG-790
BRIDLE SERIAL NO.:	BT-000727
NOTES:	
- HYDRO TEST TO 1110 PSIG FOR 10 MINUTES, TEST CERT REQ'D.	
- MATERIAL TEST REPORTS REQ'D.	
- 100% VISUAL EXAMINATION REQ'D.	
- RADIOGRAPHIC EXAMINATION ON FIRST TWO PRODUCTION WELDS REQ'D.	
- GAGE VALVES TO INCLUDE BALL CHECKS.	
- QTS HIGH TEMP COATING REQ'D (THERMALINE 4700).	
- FLEXIBLE INSULATION BLANKET REQ'D.	

1-9-37194-1

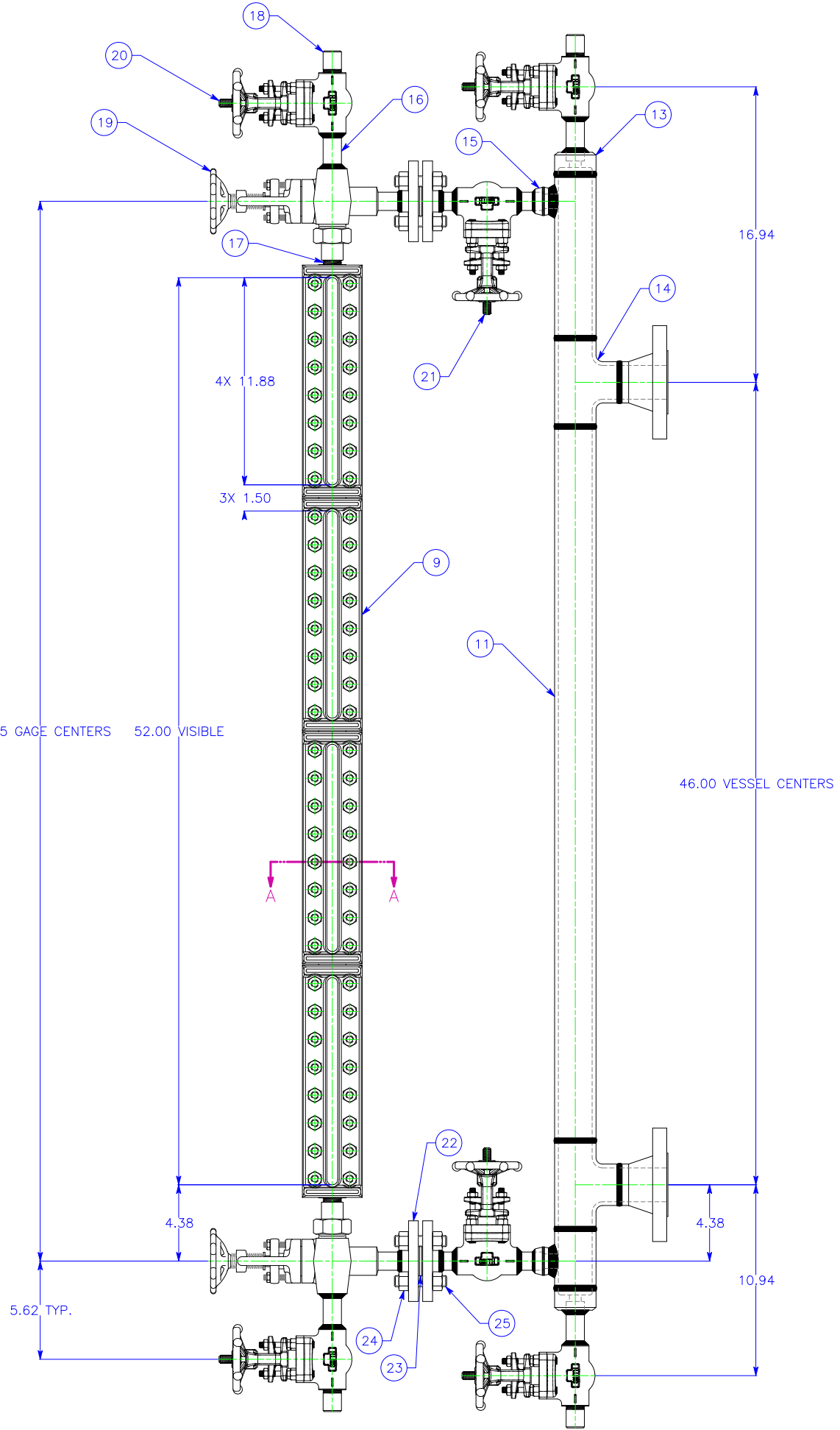
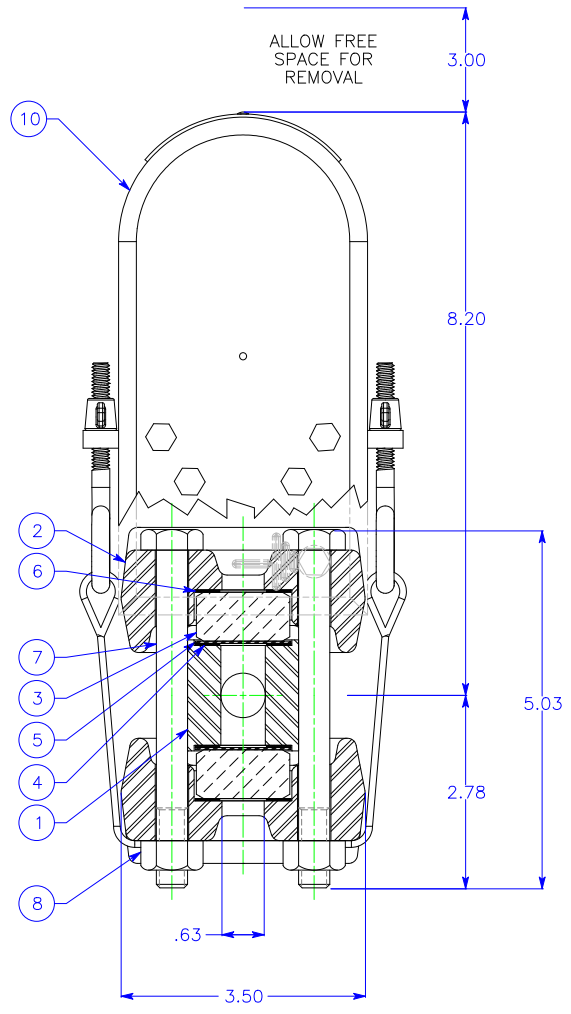
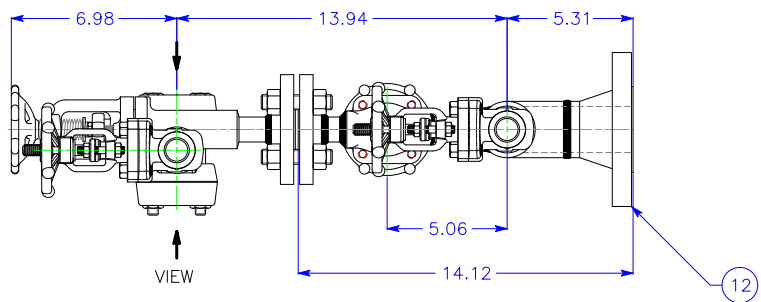

**APPROVAL DRAWINGS:**

APPROVED AS IS TO MFG.

APPROVED AS NOTED TO MFG.

NOT APPROVED-RESUBMIT BEFORE MFG.

SIGNED BY: \_\_\_\_\_

DATE: \_\_\_\_\_

THIS DRAWING IN DESIGN AND DETAIL IS OUR PROPERTY AND MUST NOT BE USED EXCEPT IN CONNECTION WITH OUR WORK. IT SHALL NOT BE REPRODUCED AND SHALL BE RETURNED TO US ON DEMAND. ALL RIGHTS ARE RESERVED.

APPROVAL DRAWING

STANDARD MANUFACTURING LIMITS UNLESS OTHERWISE SPECIFIED

UNDER 1.00 ± .03  
1.00 INCL. TO 4.00 ± .06  
4.00 AND OVER ± .13  
ANGLES ± 2°

**QTS**  
Quest-Tec Solutions  
The New Standard of Level

13960 SOUTH WAYSIDE DR.  
HOUSTON, TEXAS 77048  
(281)240-0440 FAX(281)240-2440  
E-MAIL: SALES@QTSLEVEL.COM

TITLE  
2 NPS S/80 BRIDLE WITH 84TM GAGE ASSEMBLY, 3A-U GAGE VALVES AND LED ILLUMINATOR

DRN	JLR	DATE	6/26/19	DWG NO.		REV	
CHKD	PCD	DATE	6/27/19		1-9-37194-1		0
APPD	PCD	DATE	6/27/19	SCALE	DO NOT SCALE	SHT	1 OF 1

REV	DATE	DESCRIPTION	DRN	APPD

ALL DIMENSIONS IN INCHES, UNLESS OTHERWISE SPECIFIED.

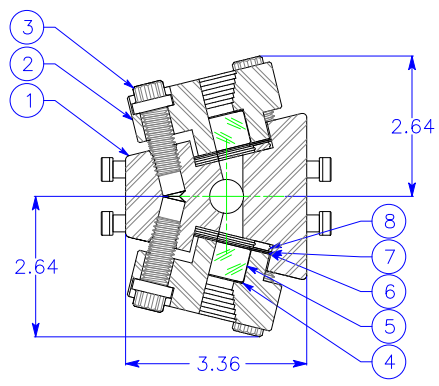

SECTION A - A  
2X  
(NOT A TRUE SECTION)

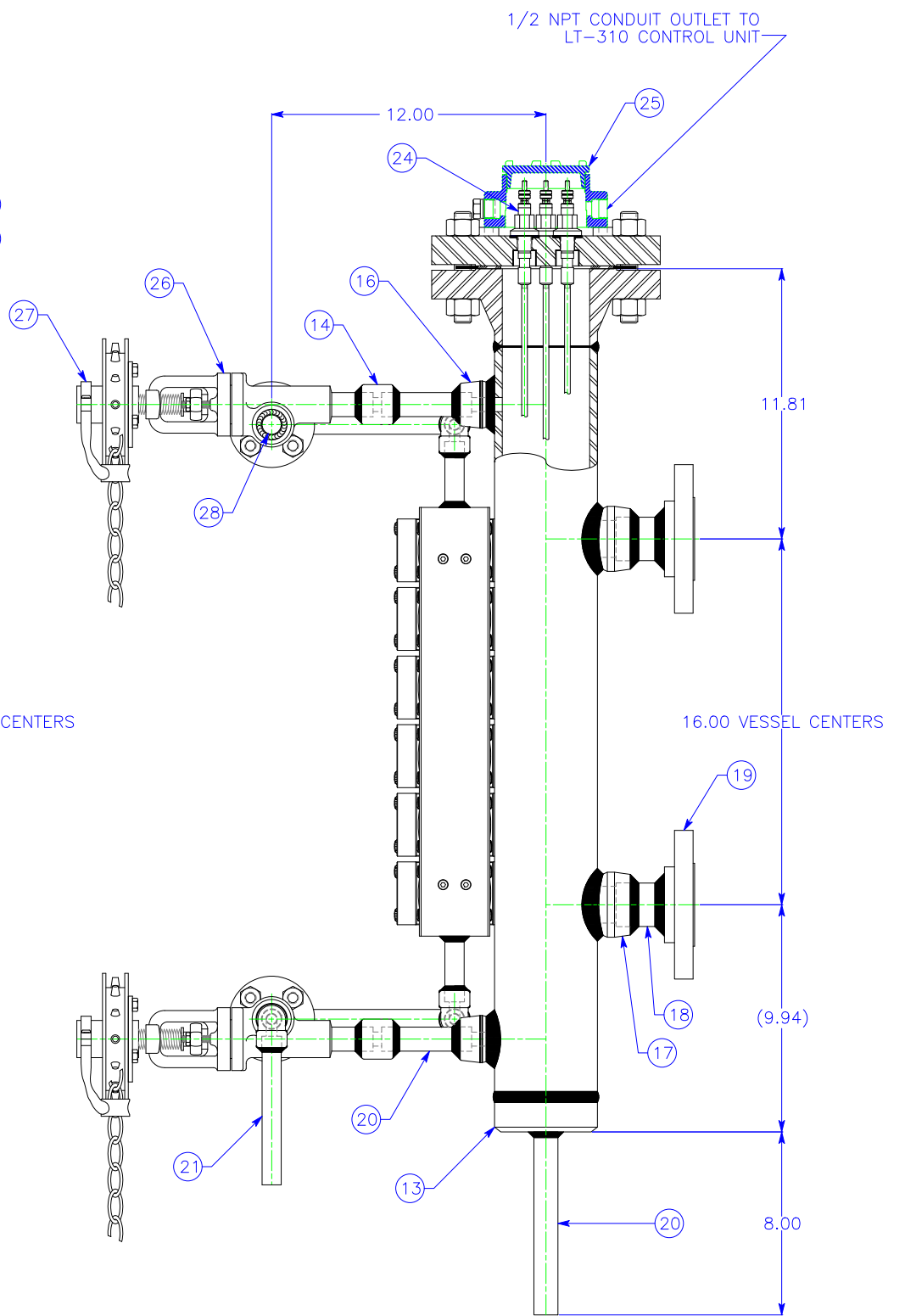
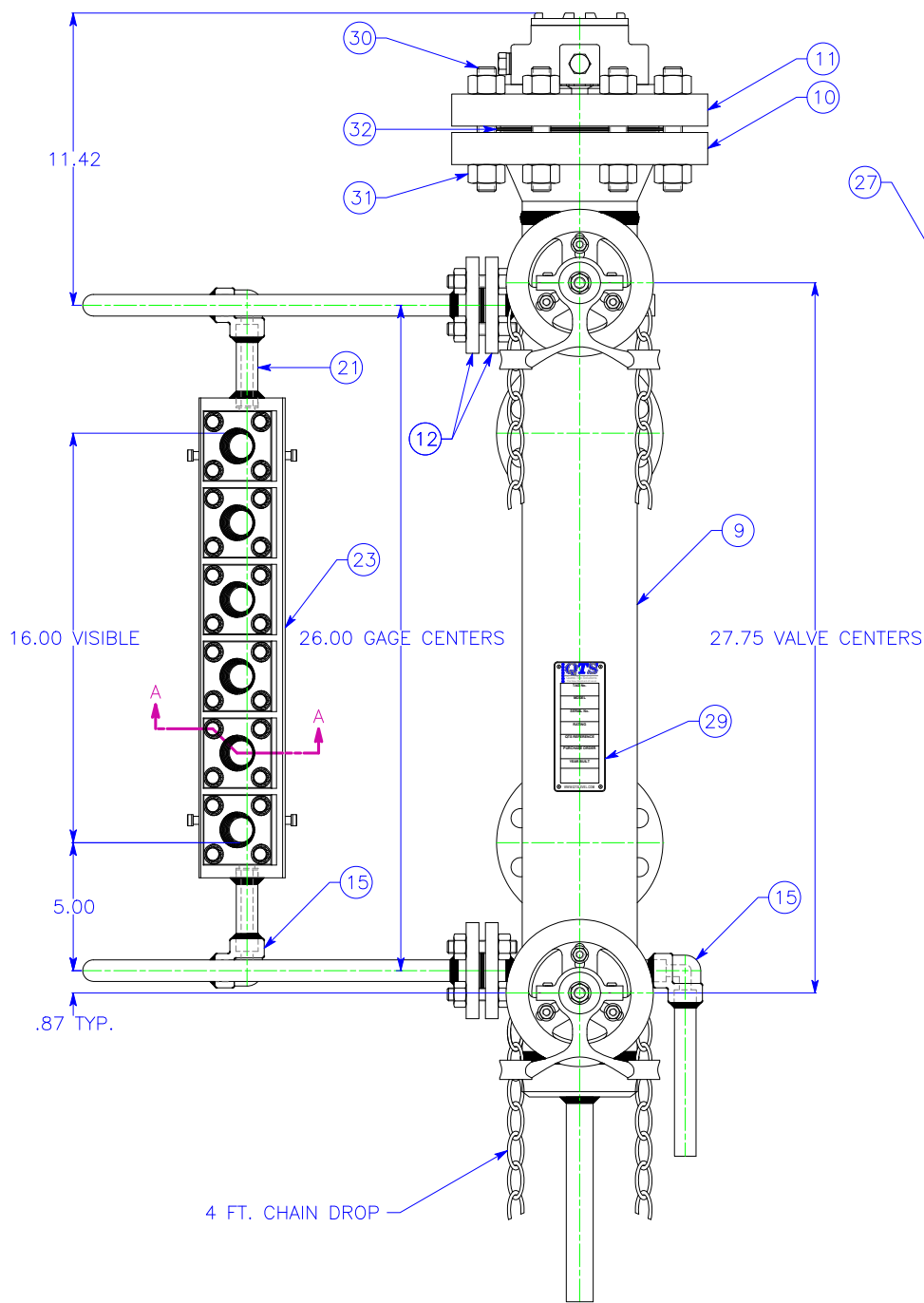
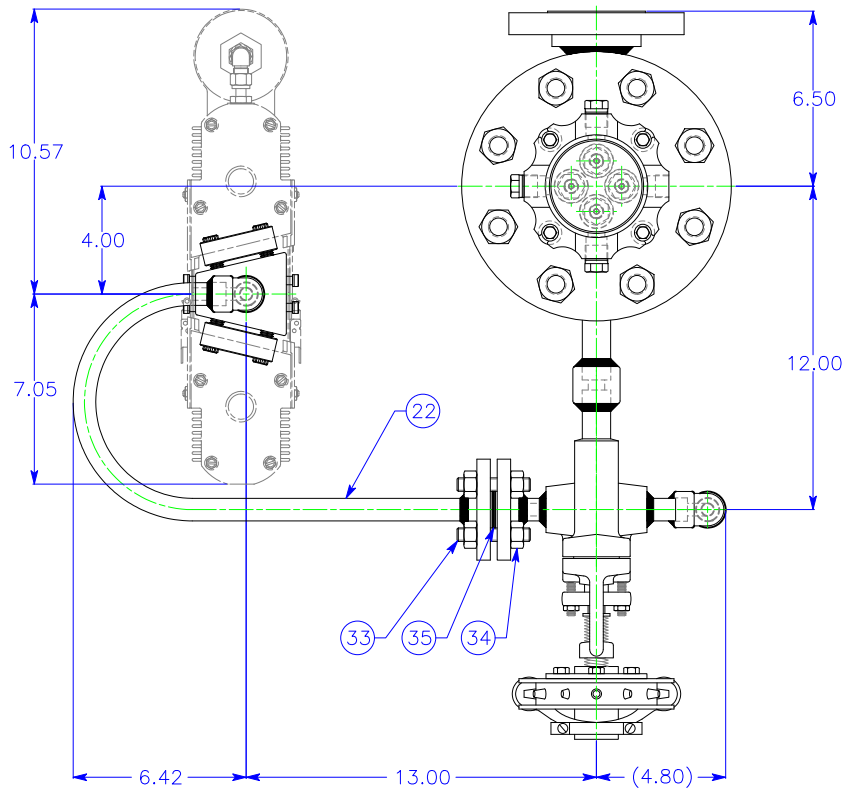

BILL OF MATERIALS

ITEM	DESCRIPTION	MATERIAL	QTY.
1	CHAMBER	304SS	1
2	COVER	SA-105	12
3	CAP SCREW	SA-193 GR. B7	48
4	SMALL CUSHION	GRAFOIL	12
5	GLASS	ALUMINOSILICATE	12
6	SHIELD	MICA	12
7	LARGE CUSHION	GRAFOIL	12
8	SPIRAL WOUND GASKET	316SS/GRAPHITE	12
9	4" SCH 80 (XS) PROBE COLUMN	SMLS SA-106B/C	1
10	4"-300# RF WN SCH 80 FLANGE	SA-105	1
11	4"-300# RF BLIND FLANGE	SA-105	1
12	1/2"-300# RF SW SCH 160 FLANGE	SA-105	4
13	4" SCH 80 BW x 3/4" SW END CAP	SA-105	1
14	3/4" 6000 SW COUPLING	SA-105	2
15	1/2" 6000# SW ELBOW 90°	SA-105	3
16	3/4" 6000# SOCKOLET	SA-105	2
17	1-1/2" 3000# SOCKOLET	SA-105	2
18	1-1/2" SCH 80 NIPPLE, PBE	SMLS SA-106B/C	2
19	2"-300# RF SW SCH 80 FLANGE	SA-105	2
20	3/4" SCH 160 PIPE NIPPLE, PBE	SMLS SA-106B/C	2
21	1/2" SCH 160 NIPPLE, PBE	SMLS SA-106B/C	5
22	1/2" SCH 160 EXPANSION LOOP	SMLS SA-106B/C	2
23	STB-3000A-06 GAGE ASSEMBLY	SEE ITEMS 1 THRU 8	1
24	MODEL 810 PROBE	316SS/ZIRCONIA OXIDE	4
25	PROBE COVER	MALLEABLE IRON	1
26	SV-1600A B16.34 900# CLASS GAGE VALVE	SA-105 BODY/13Cr TRIM/GRAF PKG	2
27	BABBITT CHAINWHEEL	ALUMINUM	2
28	1/2" SW ROUND HEAD PIPE PLUG	SA-105	1
29	QTS NAMEPLATE	304SS	1
30	3/4"-10 FULL THREAD STUD	SA193 GR. B7	8
31	3/4"-10 HEAVY HEX NUT	SA194 GR. 2H	16
32	4"-300# SPIRAL WOUND GASKET	316SS/GRAPHITE	1
33	1/2"-13 FULL THREAD STUD	SA-105 BODY/13Cr TRIM/GRAF PKG	8
34	1/2"-13 HEAVY HEX NUT	SA-194 GR. 2H	16
35	1/2"-300# SPIRAL WOUND GASKET	316SS/GRAPHITE	2
36	BI-COLOR ILLUMINATOR (PLAN VIEW ONLY)	ALUMINUM	1

NOTES:  
 1) PROBE LENGTHS TO BE CUSTOMER SPECIFIED.  
 2) EQUIPMENT RATING: 570 PSIG @ 600°F.  
 3) PER MARATHON SPECIFICATION SP-50-03-R2AA.

THIS DRAWING IN DESIGN AND DETAIL IS OUR PROPERTY AND MUST NOT BE USED EXCEPT IN CONNECTION WITH OUR WORK. IT SHALL NOT BE REPRODUCED AND SHALL BE RETURNED TO US ON DEMAND. ALL RIGHTS ARE RESERVED.

SI METRIC
THIRD ANGLE PROJECTION
ERN NO.: XXXX

REV	DATE	DESCRIPTION	DRN	APPD

ALL DIMENSIONS IN INCHES, UNLESS OTHERWISE SPECIFIED.

SUPERSEDES: \_\_\_\_\_ SUPERSEDED BY: \_\_\_\_\_

QUOTE DRAWING

STANDARD MANUFACTURING LIMITS UNLESS OTHERWISE SPECIFIED

UNDER 1.00	± .03
1.00 INCL. TO 4.00	± .06
4.00 AND OVER	± .13
ANGLES	± 2°

**QTS**  
 Quest-Tec Solutions  
 The New Standard of Level

13960 SOUTH WAYSIDE DR.  
 HOUSTON, TEXAS 77048  
 (281)240-0440 FAX(281)240-2440  
 E-MAIL: SALES@QTSLEVEL.COM

TITLE: LT-401-04 PROBE COLUMN W/  
 STB-3000A-06 GAGE & SV-1600A VALVES  
 (TAG NO. 109-F) PER QUOTE Q053119-18JAB

DRN	JLR	DATE	6/6/19	DWG NO.	1-9-060619-1	REV	0
CHKD		DATE		SCALE	NTS	SHT	1 OF 1
APPD		DATE					

BILL OF MATERIALS

1-9-30046-1

ITEM#	DESCRIPTION	MATERIAL	QTY.
1	2" SCH 40 PIPE	316 STAINLESS STEEL	3
2	2" x 2" x 2" BW TEE SCH40	316 STAINLESS STEEL	2
3	INDICATOR WIDE FLAG (BLACK & YELLOW)	316SS HOUSING / GLASS	1
4	SCALE (FT / IN)	316 STAINLESS STEEL	1
5	5/8" x 4 1/2" LG. THREADED STUD	A-193-B7 NICKEL PLATED	16
6	5/8" HEX HEAD NUT	A-194-2H NICKEL PLATED	32
7	2"-300#RF WN SCH40 FLANGE (FULL BORE)	316 STAINLESS STEEL	4
8	OBLONG FLOAT	TITANIUM	1
9	2" x 3/4"-300#RF SW SCH160 FLANGE	316 STAINLESS STEEL	2
10	SPIRAL WOUND GASKET / CENTERING RING	316SS WINDING / GRAFOIL / 316SS CENTER RING	2
11	3/4"-300#RF SW SCH160 FLANGE	316 STAINLESS STEEL	2
12	3/4" SCH160 PIPE NIPPLE	316 STAINLESS STEEL	2

**NOTE:**

- 100% X-RAY
- 100% PMI (PRESSURE RETAINING PARTS)
- 100% DYE-PEN TESTING
- HYDROTEST
- MTR'S
- F.A.T. TO CONFIRM FLOAT TRAVEL
- FULL BORE TEES
- INSULATION BLANKET AND STEAM TRACING

DIMENSIONS

ITEM	IN.	MM
A	97.00	2464
B	12.00	305
C	97.00	2464

CUSTOMER: I
FACT. REF. 30046 / 026059
SERIAL #: MT-002704
TAG#: 34-LGM-3506

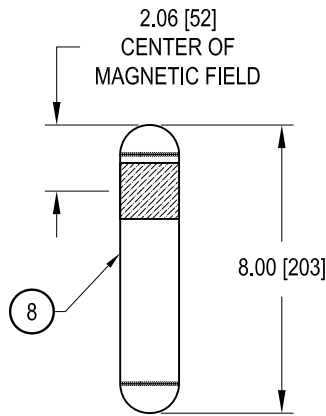

FLOAT  
 DESIGN SPECIFIC GRAVITY: 1.00  
 MAX. DESIGN PRESSURE: 95 psig  
 MAX. DESIGN TEMPERATURE: 300°F

**APPROVAL DRAWINGS:**

- APPROVED AS IS TO MFG.
  - APPROVED AS NOTED TO MFG.
  - NOT APPROVED-RESUBMIT BEFORE MFG.
- SIGNED BY: \_\_\_\_\_ DATE: \_\_\_\_\_
- DRAWING TO BE RETURNED TO QTS BY: \_\_\_\_\_ TO AVOID DELAY.

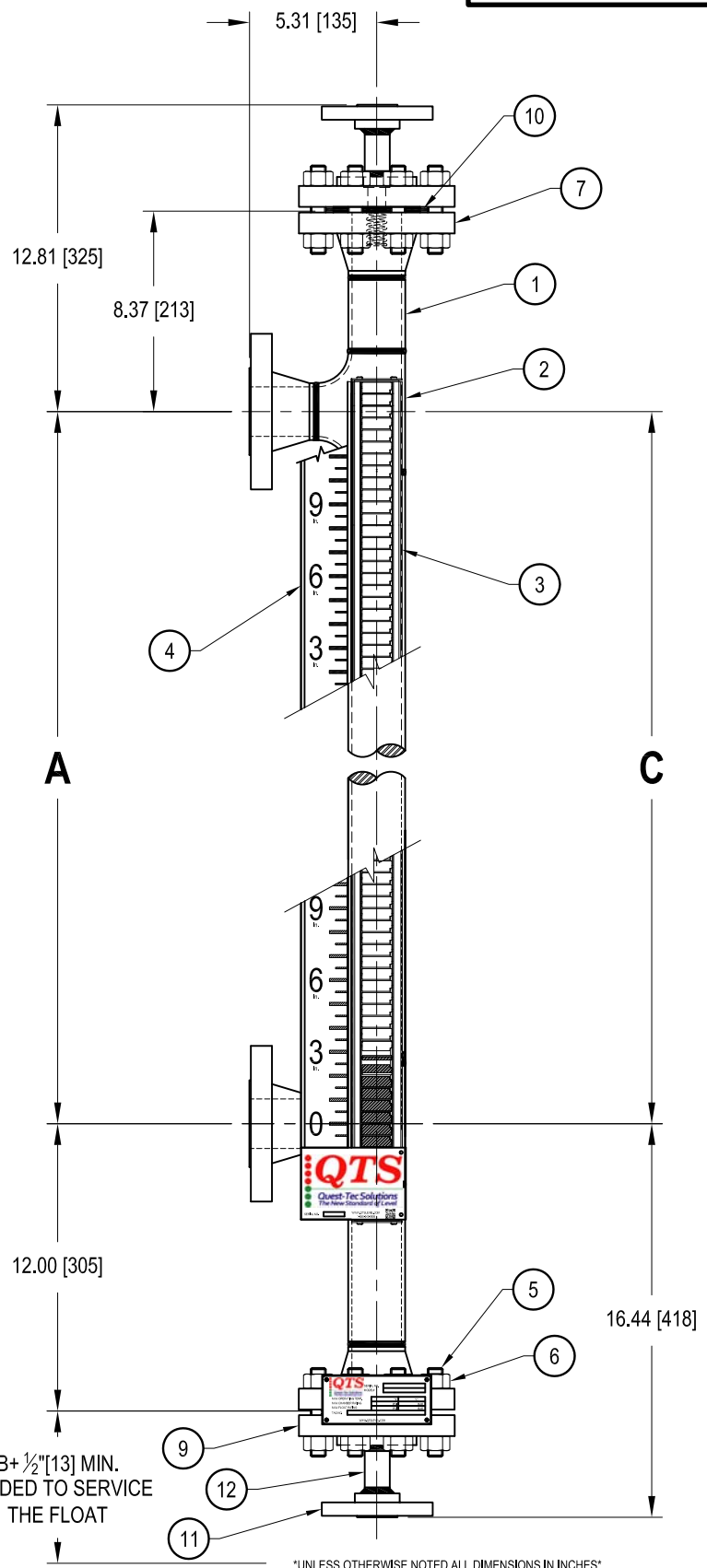

B + 1/2" [13] MIN.  
 NEEDED TO SERVICE  
 THE FLOAT

\*UNLESS OTHERWISE NOTED ALL DIMENSIONS IN INCHES\*

THIS DRAWING IN DESIGN AND DETAIL IS OUR PROPERTY AND MUST NOT BE USED EXCEPT IN CONNECTION WITH OUR WORK. IT SHALL NOT BE REPRODUCED AND SHALL BE RETURNED TO US ON DEMAND. ALL RIGHTS ARE RESERVED.

STANDARD MANUFACTURING LIMITS  
 UNLESS OTHERWISE SPECIFIED

- X.XX ±.015
- X.XXX ±.005
- ANGULAR ±0° 30'
- FINISH 200 RA MAX
- FRACTIONAL ± 1/64



1380 SOUTH WAYSIDE DR.  
 HOUSTON, TEXAS 77047  
 (281) 984-8488 FAX (281) 984-8480  
 EMAIL: SALES@QUESTTECSOLUTIONS.COM

TITLE  
 2" SCH40 MAGNE-TRAC LEVEL GAGE  
 MT-6S-D-16-03.1.0-95-300-97-WF-CS-WN-BW-SH-HB-ST

DRN	RET	DATE	2/19/16	DWG NO.		REV	
CHKD	GG	DATE	2/19/16	A	1-9-30046-1	0	
APPD	GG	DATE	2/19/16	SCALE	NTS	SHT	1 OF 1

SI METRIC

THIRD ANGLE PROJECTION

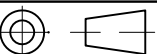

REV	DATE	DESCRIPTION	DRN	APPD

BREAK ALL SHARP CORNERS TO .003-.015  
 RADIUS AND REMOVE ALL BURRS

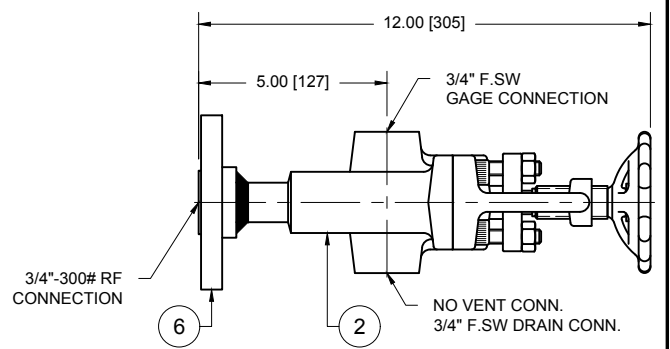
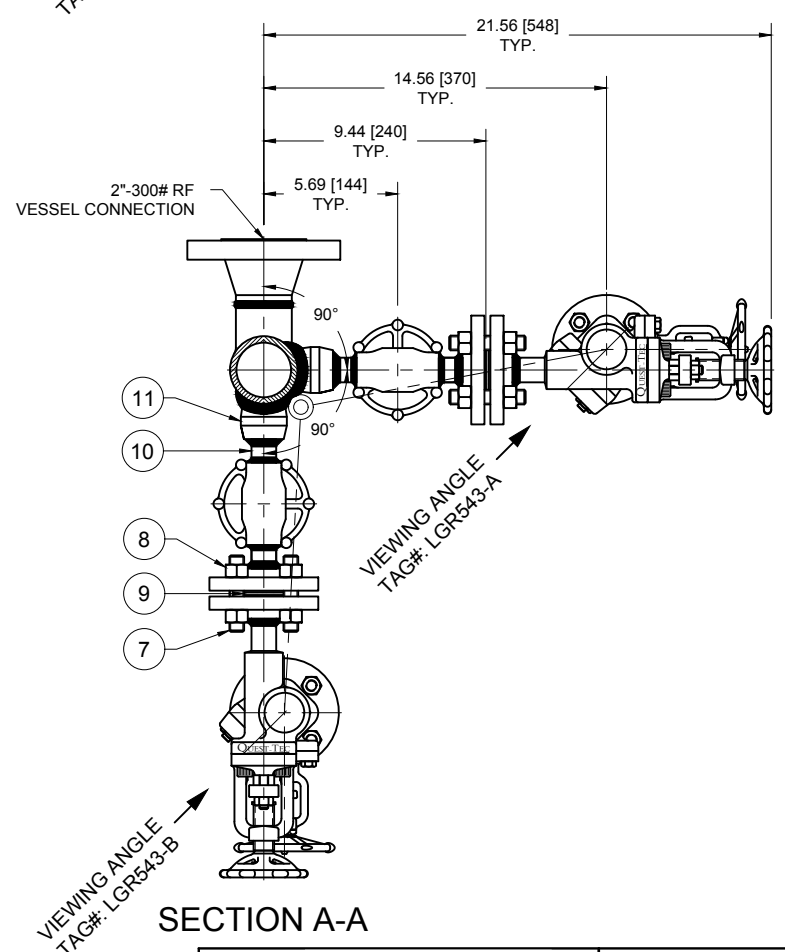
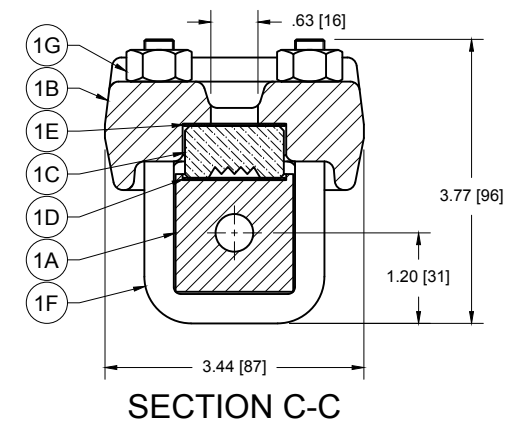
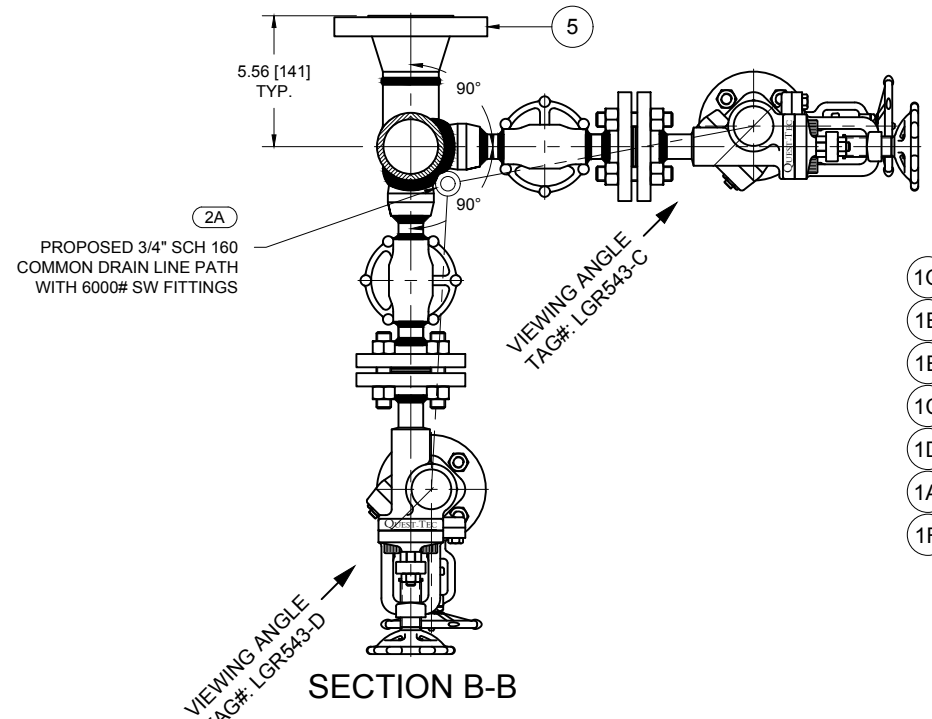
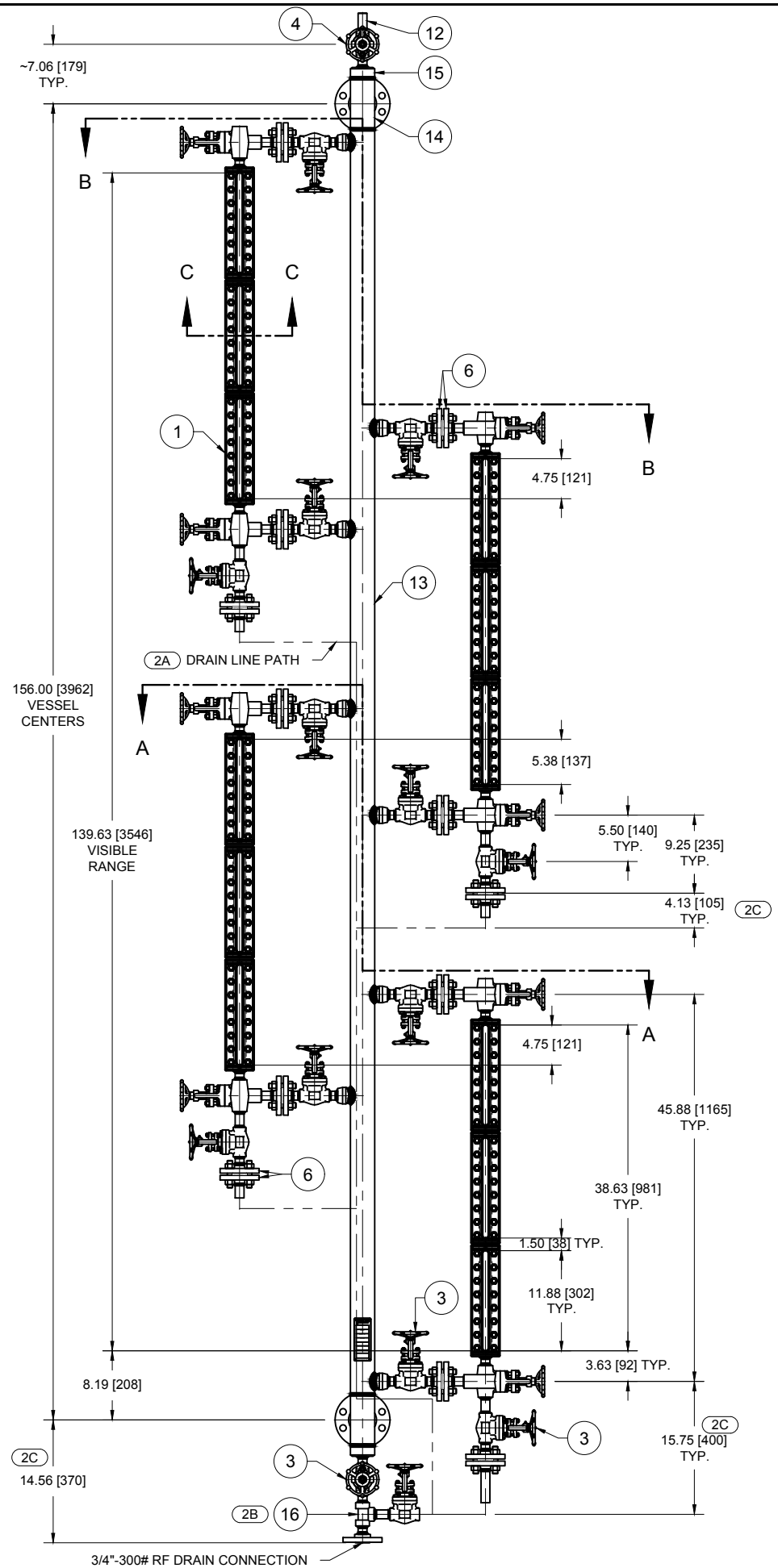

BILL OF MATERIALS		
ITEM#	DESCRIPTION	MATERIAL
1	83RM LEVEL GAGE ASSEMBLY (QTY: 4)	SEE 1A - 1G
1A	CHAMBER	CARBON STEEL
1B	COVER	CARBON STEEL
1C	GLASS	TEMPERED BOROSILICATE
1D	GASKET	GRAFOIL
1E	CUSHION	GRAFOIL
1F	U-BOLT	SA-193 B7
1G	NUT	SA-194 2H
2	3A-S VALVE ASSEMBLY	CS BODY / 316 SS TRIM / GRAFOIL PACKING
3	3/4\"/>	
4	3/4\"/>	
5	2\"/>	
6	3/4\"/>	
7	1/2\"/>	
8	1/2\"/>	
9	300# SPIRAL WOUND GASKET w/ CENTERING RING	304 SS / GRAPHITE
10	3/4\"/>	
11	3/4\"/>	
12	3/4\"/>	
13	2-1/2\"/>	
14	2-1/2\"/>	
15	END CAP	CARBON STEEL
16	3/4\"/>	

REV	DATE	DESCRIPTION	DRN	APPD
2	8/10/16	2A) ADD PHANTOM LINE FOR DRAIN PIPING. 2B) ADD ITEM# 16. 2C) REVISE DIMENSIONS TO REFLECT CHANGES MADE.	PCD	JLR
1	7/12/16	1A) ITEMS "1D" & "1E" WERE GARLOCK NOW GRAFOIL. 1B) ITEMS "3" & "4" WERE API 12 TRIM NOW API 8 TRIM. 1C) ITEMS "7" & "8" NOW TFE COATED. 1D) ITEM "9" WAS 316 SS NOW 304 SS. 1E) PT WAS 10% NOW 100%. RT WAS 10% NOW 10% SW & 10% BW, ADD HYDROSTATIC TEST.	PCD	JLR

<b>CUSTOMER:</b>	<b>TAG#:</b>
CUST. PO#: 4455976	BRIDLE:
FACT.REF.: 30465 / 026436	LGR543
<b>END USER:</b>	<b>GAGES:</b>
LGR543-D	LGR543-C
LGR543-B	LGR543-A
<b>END USER P/O#:</b>	
<b>TESTING &amp; DOCUMENTATION:</b> (1E)	
1) MATERIAL TEST REPORTS.	
2) DYE-PEN 100%	
3) X-RAY 10% SW & 10% OF BW	
4) VISUAL TEST 100%	
5) HYDROSTATIC TEST AT 1110 psig FOR 30 MIN.	

**APPROVAL DRAWING:**

APPROVED AS IS TO MFG.

APPROVED AS NOTED TO MFG.

NOT APPROVED-RESUBMIT BEFORE MFG.

SIGNED BY: \_\_\_\_\_ DATE: \_\_\_\_\_

DRAWING TO BE RETURNED TO QTS BY: \_\_\_\_\_ TO AVOID DELAY.

THIS DRAWING IN DESIGN AND DETAIL IS OUR PROPERTY AND MUST NOT BE USED EXCEPT IN CONNECTION WITH OUR WORK. IT SHALL NOT BE REPRODUCED AND SHALL BE RETURNED TO US ON DEMAND. ALL RIGHTS ARE RESERVED.

SI METRIC  
THIRD ANGLE PROJECTION

UNLESS OTHERWISE NOTED ALL DIMENSIONS IN INCHES [mm]

**QTS**  
Quest-Tec Solutions  
The New Standard of Level

13980 SOUTH WAYSIDE DR.  
HOUSTON, TEXAS 77048  
OFFICE (281)240-0440  
FAX (281)240-2440  
WWW.QTSLlevel.com

TITLE (4) 83RM LEVEL GAGES w/ 3-S VALVE ASSEMBLIES  
ON 2-1/2" SCH 80 BRIDLE  
PER JOB# 026436 FCX PERFORMANCE, INC.

DRN	PCD	DATE	6/27/16	SIZE	DRAWING #	REV
CHKD	RET	DATE	6/28/19	B	1-9-30465-3	2
APPD	RET	DATE	6/28/19	SCALE	N.T.S.	SHEET 1 OF 1

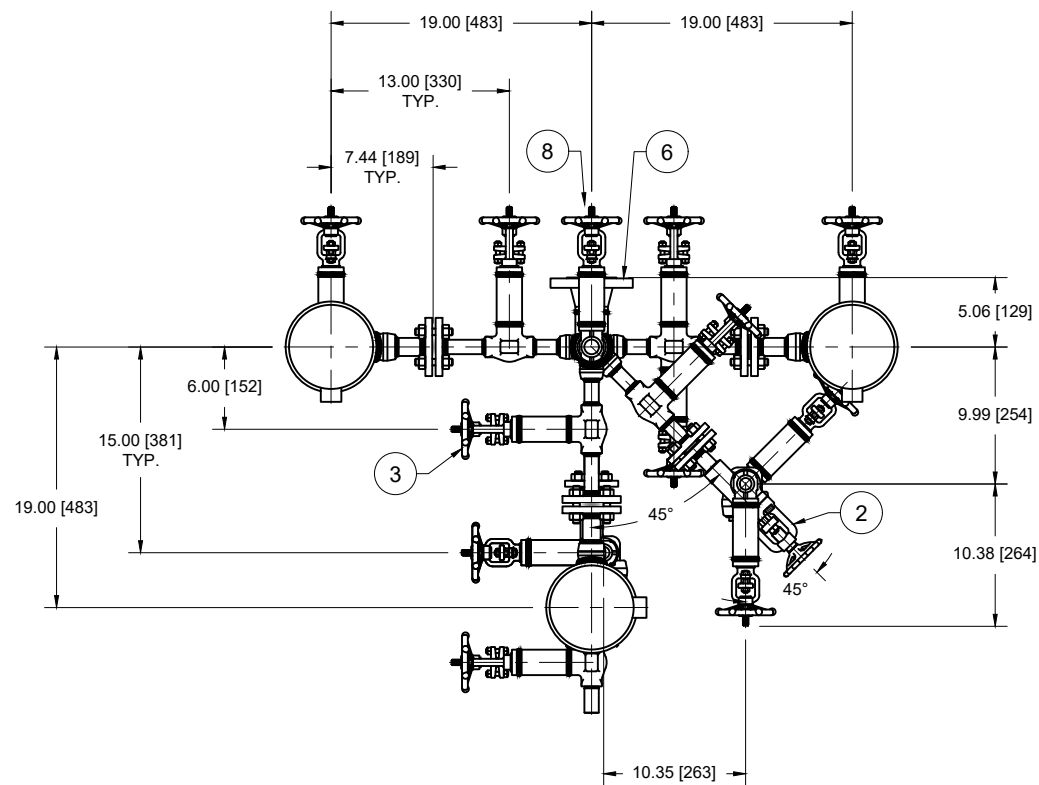

BILL OF MATERIALS			
ITEM#	DESCRIPTION	MATERIAL	QTY:
1	83RM LEVEL GAGE	SEE ITEM#S 1A- 1G	2
1A	CHAMBER	SA-696 Gr C CS	1 PER
1B	COVER	SA-105 CS	3 PER
1C	GLASS	TEMPERED BOROSILICATE	3 PER
1D	GASKET	GRAFOIL	3 PER
1E	CUSHION	GARLOCK IFG-5500	3 PER
1F	U-BOLT	SA-193 B7	24 PER
1G	NUT	SA-194 2HM	48 PER
2	3A-S VALVE ASSEMBLY	SA-105 CS BODY / 416 SS TRIM / GRAFOIL PACKING	2 SETS
3	3/4" CL800 SW GATE VALVE (BELLOW SEAL)	SA-105 CS BODY / API 5 TIRM	14
4	3/4" CL800 SW x NPT GATE VALVE (BELLOW SEAL)	SA-105 CS BODY / API 5 TIRM	7
5	1/2" CL800 SW x NPT GATE VALVE (BELLOW SEAL)	SA-105 CS BODY / API 5 TIRM	4
6	2"-150# RF WN SCH 80 FLANGE	SA-105 CS	2
7	1" x 3/4"-150# RFSW SCH 160 FLANGE	SA-105 CS	10
8	3/4"-150# RFSW SCH 160 FLANGE	SA-105 CS	8
9	2" SCH 80 BW TEE	SA-234 WPB CS	2
10	3/4" 3000# SOCK-O-LET	SA-105 CS	14
11	3/4" 3000# SW TEE	SA-105 CS	6
12	3/4" NPT ROUND HEAD PLUG	SA-105 CS	8
13	1/2" NPT ROUND HEAD PLUG	SA-105 CS	4
14	2" SCH 80 PIPE	SA-106B CS	3
15	3/4" SCH 160 PIPE	SA-106B CS	43
16	1/2" SCH 160 PIPE	SA-106B CS	8
17			
18	2" SCH 80 BW x 3/4" F.SW END CAP	SA-105 CS	2
19	5/8"-11 STUD	SA-193 B7	56
20	5/8"-11 NUT	SA-194 2H	112
21	1" 150# SPIRAL WOUND GASKET	316 SS / GRAPHITE	10
22	3/4" 150# SPIRAL WOUND GASKET	316 SS / GRAPHITE	4
23	FLOAT SWITCH	CUSTOMER SUPPLIED	5

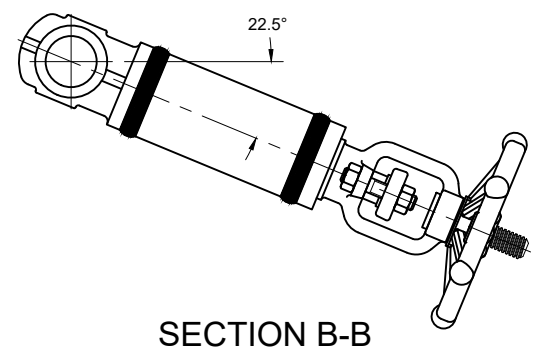
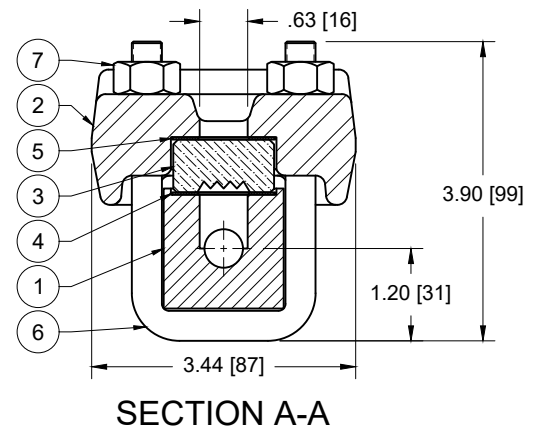
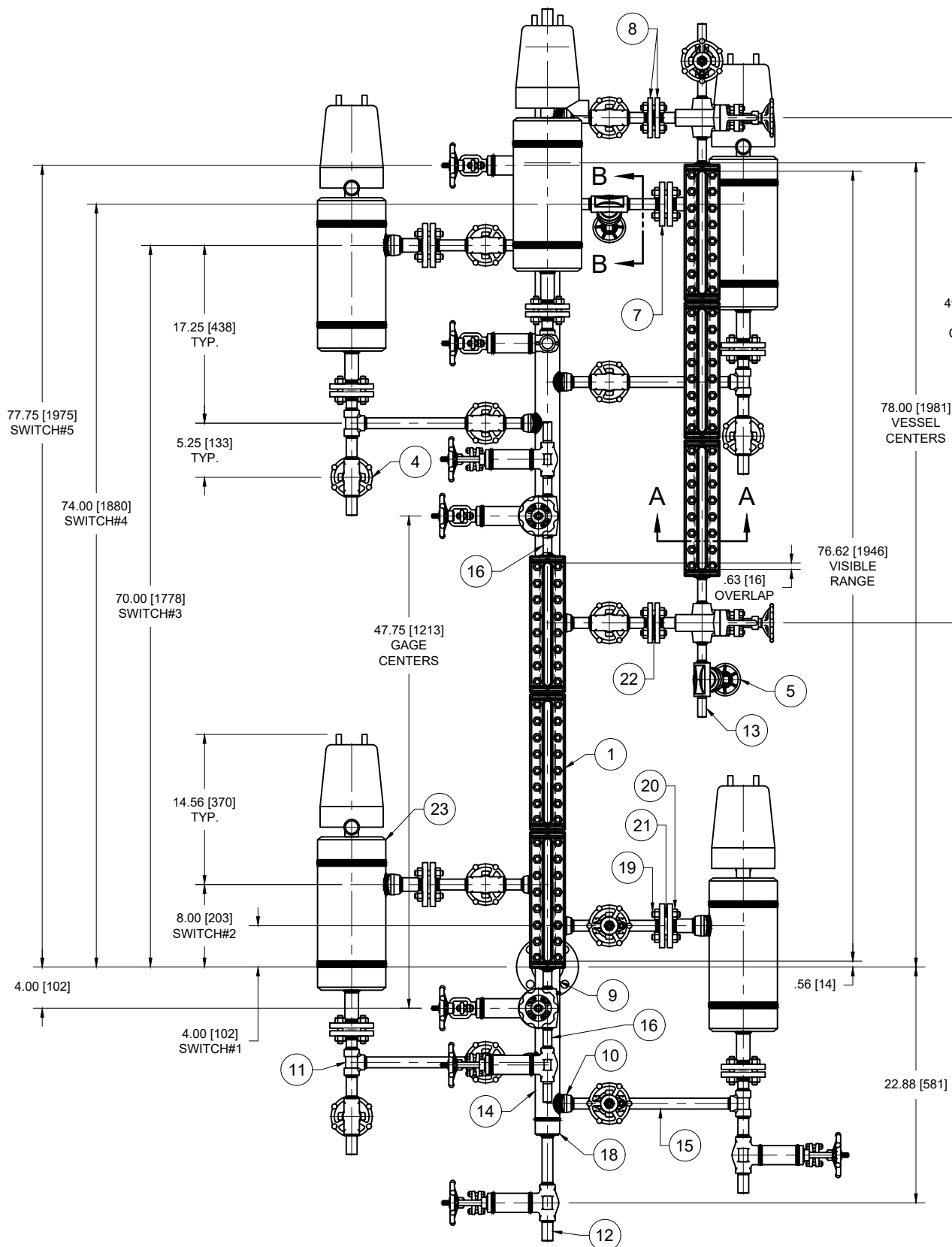

**CUSTOMER:**  
**CUST. PO#:**  
**FACT.REF.:** 37980 / 032893  
**TAG#:**  
**RATING:** 285 PSI @ 100° F / 170 PSI @ 500° F  
**TESTING & DOCUMENTATION:**  
 1) HYDROSTATIC TEST AT 428 PSIG.  
 2) MATERIAL TEST REPORTS.  
 3) X-RAY 5% OF WELDS.  
 4) LEVEL II VISUAL TEST 5%.

**APPROVAL DRAWING:**

APPROVED AS IS TO MFG.  
 APPROVED AS NOTED TO MFG.  
 NOT APPROVED-RESUBMIT BEFORE MFG.

SIGNED BY: \_\_\_\_\_  
 DATE: \_\_\_\_\_

**NOTES**

- TRUE ORIENTATION SHOWN IN PLAN VIEW.
- COATING PER 12.1 PAINT SPEC.

THIS DRAWING IN DESIGN AND DETAIL IS OUR PROPERTY AND MUST NOT BE USED EXCEPT IN CONNECTION WITH OUR WORK. IT SHALL NOT BE REPRODUCED AND SHALL BE RETURNED TO US ON DEMAND. ALL RIGHTS ARE RESERVED.

SI METRIC  
 THIRD ANGLE PROJECTION

REV	DATE	DESCRIPTION	DRN	APPD
2	12/6/19	REMOVE DRAIN VALVES AND FLANGE	PCD	RET
1	12/4/19	REVISE DRAWING PER MARK UPS.	PCD	JB

UNLESS OTHERWISE NOTED ALL DIMENSIONS IN INCHES [mm]

**QTS**  
 Quest-Tec Solutions  
 The New Standard of Level

13960 SOUTH WAYSIDE DR.  
 HOUSTON, TEXAS 77048  
 OFFICE (281)240-0440  
 FAX (281)240-2440  
 WWW.QTSLlevel.com

TITLE: 2" SCH 80 BRIDLE w/ (2) 83RM LEVEL GAGE & 3A-S VALVE ASSEMBLY & (5) FLOAT SWITCH  
 PER JOB# 032893

DRN	PCD	DATE	SIZE	DRAWING #	REV
CHKD	RET	DATE	B	1-9-37980-1	2
APPD	RET	DATE	SCALE	N.T.S.	SHEET 1 OF 1

BILL OF MATERIALS

1-9-28670-2

ITEM#	DESCRIPTION	MATERIAL	QTY.
1	3" SCH 40 PIPE	304 STAINLESS STEEL	1
2	3"-150#RF SO FLANGE	304 STAINLESS STEEL	1
3	1" SCH 80 PIPE NIPPLE	304 STAINLESS STEEL	2
4	1"-150#RF RED. SCH 80 FLANGE	304 STAINLESS STEEL	2
5	½" SW END CAP	304 STAINLESS STEEL	1
6	½" 3000# SOCK-O-LET	304 STAINLESS STEEL	1
7	½" SCH80 PIPE NIPPLE	304 STAINLESS STEEL	2
8	½" F.NPT x F.SW CL 800# GATE VALVE	304 STAINLESS STEEL	2
9	½" M.NPT BULL PLUG	304 STAINLESS STEEL	2
10	1" 3000# SOCK-O-LEET	304 STAINLESS STEEL	2

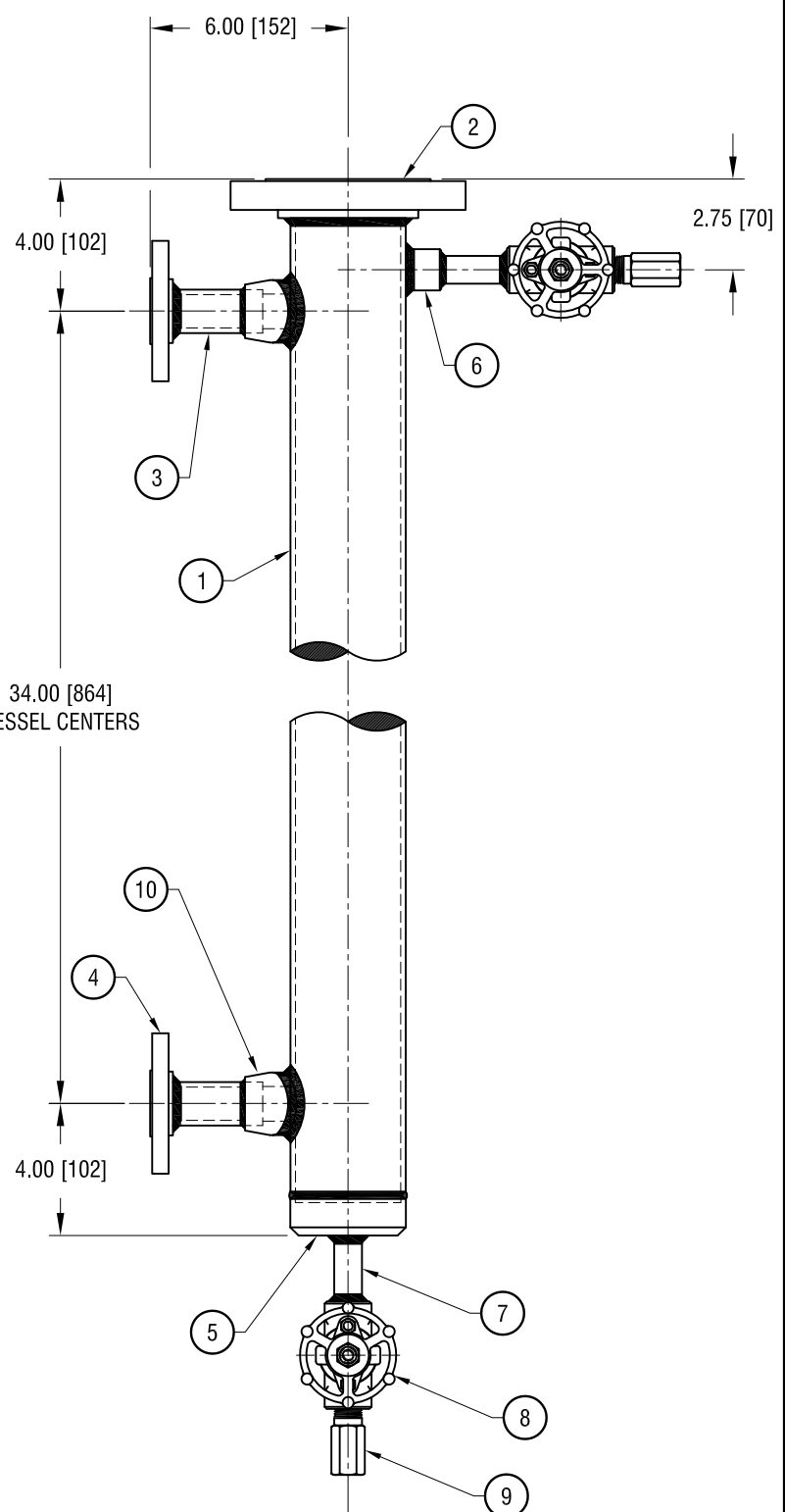

CUSTOMER:
CUST. P.O.#:
FACT. REF. 28670 / 024930
SERIAL #:
TAG#:
END USER:
END USER PO.#:

\*UNLESS OTHERWISE NOTED ALL DIMENSIONS IN INCHES\*

REV	DATE	DESCRIPTION	DRN	APPD

THIS DRAWING IN DESIGN AND DETAIL IS OUR PROPERTY AND MUST NOT BE USED EXCEPT IN CONNECTION WITH OUR WORK. IT SHALL NOT BE REPRODUCED AND SHALL BE RETURNED TO US ON DEMAND. ALL RIGHTS ARE RESERVED.

STANDARD MANUFACTURING LIMITS UNLESS OTHERWISE SPECIFIED

X.XX ±.015  
 X.XXX ±.005  
 ANGULAR ±0° 30'  
 FINISH 200 RA MAX  
 FRACTIONAL ± 1/64

BREAK ALL SHARP CORNERS TO .003-.015 RADIUS AND REMOVE ALL BURRS

**QTS** Quest-Tec Solutions  
 The New Standard of Level

13800 SOUTH WYNDLE DR.  
 HOUSTON, TEXAS 77046  
 (281) 284-0400 FAX (281) 284-0400  
 E-MAIL: SALES@QUESTTECSOLUTIONS.COM

TITLE: **EXAMPLE DRAWING D28670**

DRN	RET	DATE	6/29/15	DWG NO.	1-9-28670-2	REV	0
CHKD		DATE		A			
APPD		DATE		SCALE	NTS	SHT	1 OF 1

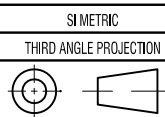

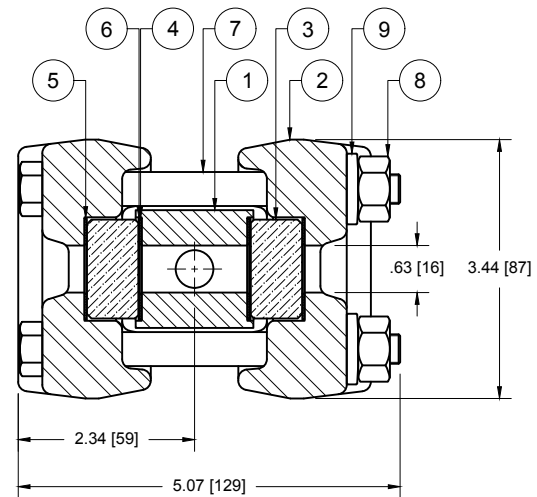
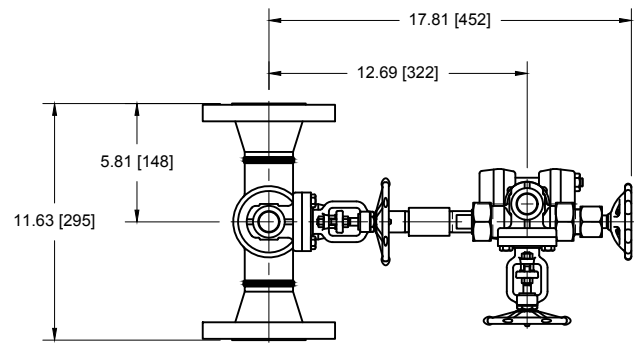

SECTION A-A

BILL OF MATERIALS		
ITEM#	DESCRIPTION	MATERIAL (2B)
1	CHAMBER	SA-696 GR C CS
2	COVER	SA-105 CS
3	GLASS	TEMPERED BOROSILICATE
4	GASKET	GRAFOIL
5	CUSHION	GARLOCK IFG-5500
6	SHIELD	MICA, HQ 0.009-0.012
7	BOLT	SA-193 B7
8	NUT	SA-194 2H
9	SPRING WASHERS	17-7 PH SS
10	2-U VALVE ASSEMBLY	SA-105 CS BODY / A582 TYPE 416 SS TRIM / GRAFOIL PACKING
11	3/4" CL800 SW x NPT SMITH GATE VALVE	SA-105 CS BODY / API #8 TRIM
12	3/4" SCH 80 PIPE NIPPLE	SA-106 B SEAMLESS PIPE
13	3/4" NPT ROUND HEAD PLUG	SA-105 CS
14	3/4" 3000# NPT COUPLING	SA-105 CS
15	3/4" SCH 80 M.NPT NIPPLE	SA-106 B SEAMLESS PIPE
16	3/4" 3000# THREAD-O-LET	SA-105 CS
17	3" SCH 80 PIPE NIPPLE	SA-106 B SEAMLESS PIPE
18	3" SCH 80 x 3/4" SW END CAP	SA-105 CS
19	3" x 3" x 2" SCH 80 BW TEE	SA-234 WPB CS
20	2"-300# RF WN SCH 80 FLANGE	SA-105 CS
21	1/2" SCH 160 M.NPT NIPPLE	SA-160 B SEAMLESS PIPE

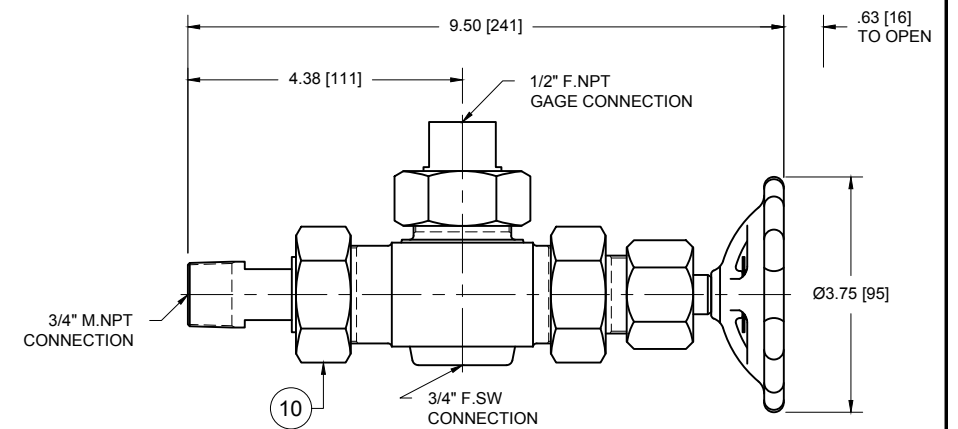
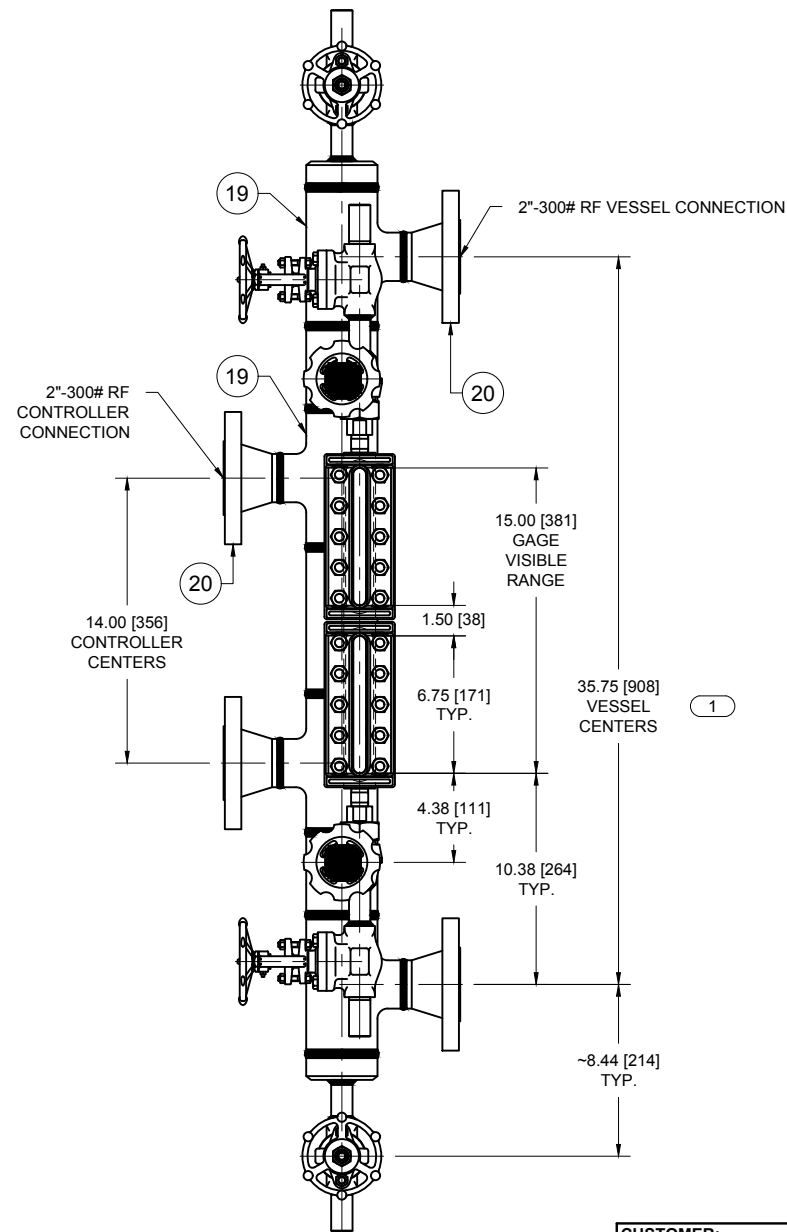
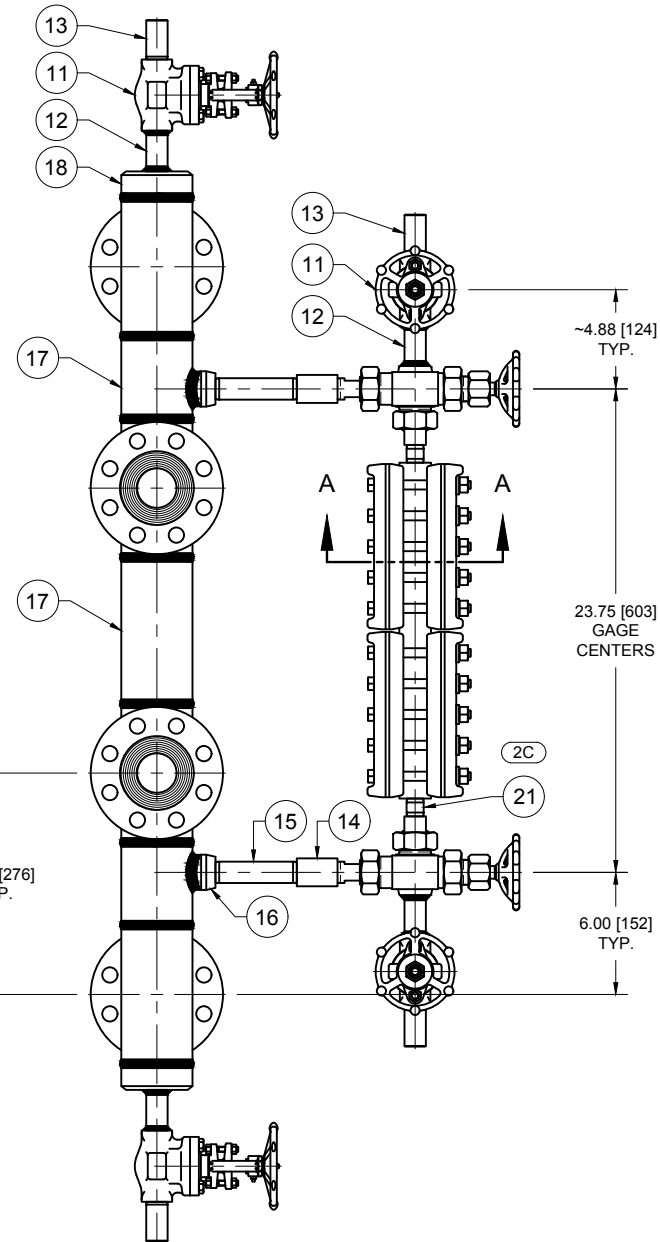

VALVE VIEW

REV	DATE	DESCRIPTION	DRN	APPD
2	8/9/16	2A) ADD TIME FOR HYDROSTATIC TEST. 2B) REVISE MATERIAL SPECS IN BOM. 2C) ADD ITEM# 21 TO BOM.	PCD	RET
1	8/4/16	CORRECT VESSEL CENTERS	PCD	RET

**CUSTOMER:**  
**CUST. PO#:**  
**FACT.REF.:**  
**TAG#:**  
**END USER:**  
**END USER P/O#:** 5  
**TESTING & DOCUMENTATION:**  
 1) HYDROSTATIC TEST AT 1110 psig FOR 30 min.  
 2) MATERIAL TEST REPORTS.  
 3) DYE-PEN 100%  
 4) RT (SW JOINTS) 10%  
 5) RT (BW JOINTS) 10%

**APPROVAL DRAWING:**  
 APPROVED AS IS TO MFG.  
 APPROVED AS NOTED TO MFG.  
 NOT APPROVED-RESUBMIT BEFORE MFG.  
 SIGNED BY: \_\_\_\_\_ DATE: \_\_\_\_\_  
 DRAWING TO BE RETURNED TO QTS BY: \_\_\_\_\_ TO AVOID DELAY.

THIS DRAWING IN DESIGN AND DETAIL IS OUR PROPERTY AND MUST NOT BE USED EXCEPT IN CONNECTION WITH OUR WORK. IT SHALL NOT BE REPRODUCED AND SHALL BE RETURNED TO US ON DEMAND. ALL RIGHTS ARE RESERVED.  
 SI METRIC  
 THIRD ANGLE PROJECTION

UNLESS OTHERWISE NOTED ALL DIMENSIONS IN INCHES [mm]

**QTS**  
 Quest-Tec Solutions  
 The New Standard of Level  
 13980 SOUTH WAYSIDE DR.  
 HOUSTON, TEXAS 77048  
 OFFICE (281)240-0440  
 FAX (281)240-2440  
 WWW.QTSLlevel.com

TITLE: 3" SCH 80 BRIDLE w/ 42TM LEVEL GAGE &  
 EXAMPLE DRAWING D30937

DRN	PCD	DATE	8/4/16	SIZE	DRAWING #	REV
CHKD	RET	DATE	8/4/16	B	1-9-30937-1	2
APPD	RET	DATE	8/4/16	SCALE	N.T.S.	SHEET 1 OF 1

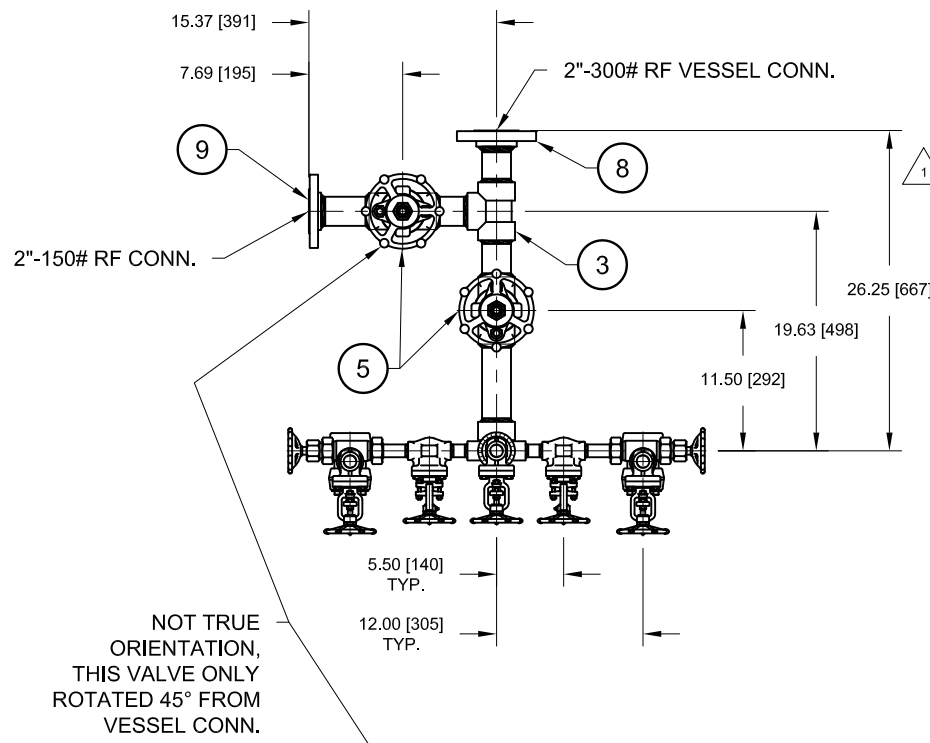

<b>CUSTOMER:</b>
<b>CUST. PO#:</b>
<b>FACT.REF.:</b> 25876 / 022430
<b>TAG#:</b> AR-LG-613
<b>PURCHASER'S NAME:</b> JACOBS FIELD SERVICES NORTH AMERICA
<b>PROJECT NAME:</b> ARU 606-E RECOVERY TOWER LIQUID LEVEL GAUGE.
<b>AGENTS PROJECT#:</b> D2650-647693
<b>SELLERS JOB#:</b> 1751260
<b>TESTING &amp; DOCUMENTATION:</b> 1) HYDROSTATIC TEST AT 428 PSI FOR 1 HOUR ON CHART RECORDER, TO BE WITNESSED BY INSPECTOR. 2) MATERIAL TEST REPORTS. 3) ITP REPORT. 4) VISUAL TEST BY LEVEL 2 INSPECTOR. 5) X-RAY 10% OF WELDS. 6) DYE-PEN 100% OF WELDS. 7) ULTRASONIC TESTING ON 100% OF 3/4" SCH 160 NIPPLES.
<b>NOTES:</b> 1) ASSEMBLY TO BE COATED PER TCR-GP-06-60-1 TABLE 13 - COATING SYSTEM BP-8A. 2) WELDING TO BE PER QTS EQUIVALENT OF WPS BARO 2 REV 2 & TO HAVE A MINIMUM OF 3 PASSES WITH TWO VISIBLE COVER PASSES. ER70S-2 ESAB ARCALOY SOLID WELD WIRE TO BE USED. 3) STEAM TRACING BY OTHERS. 4) INSULATION BLANKET BY OTHERS.

BILL OF MATERIALS			
ITEM#	DESCRIPTION	MATERIAL	QTY
1	94TM GAGE ASSEMBLY W/ 2-U VALVES	SEE DWG. 1-9-25876-2	3
2	2" SCH 80 PIPE NIPPLE PBE	CARBON STEEL	17
3	2" 3000# SW TEE	CARBON STEEL	4
4	2" X 2" X 3/4" 3000# SW TEE	CARBON STEEL	6
5	2" 800# SW GATE VALVE	CS BODY / API TRIM #8 (GRAFOIL PACKING)	4
6	3/4" 800# SW GATE VALVE	CS BODY / API TRIM #8 (GRAFOIL PACKING)	6
7	3/4" 800# SW X THD GATE VALVE	CS BODY / API TRIM #8 (GRAFOIL PACKING)	8
8	2"-300# RFSW SCH 80 FLANGE	CARBON STEEL	2
9	2"-150# RFSW SCH 80 FLANGE	CARBON STEEL	2
10	2" SCH 80 X 3/4" SCH 160 REDUCING SWAGE	CARBON STEEL	2
11	3/4" SCH 160 PIPE NIPPLE PBE	CARBON STEEL	12
12	3/4" NPT BULL PLUG	410 SS	8

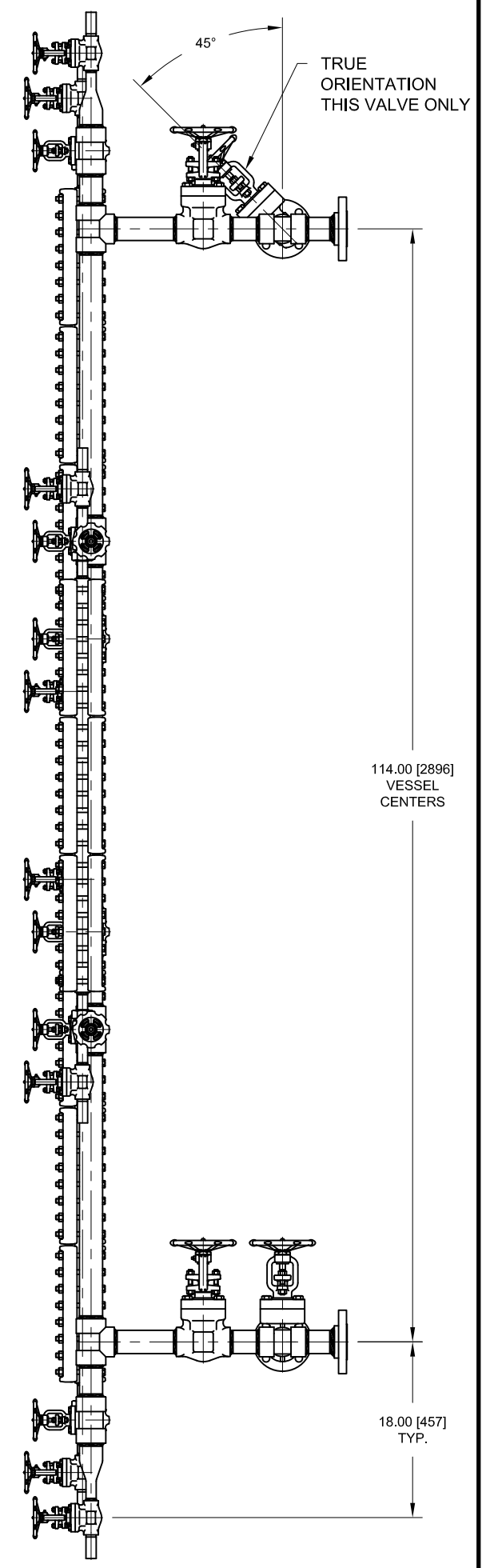
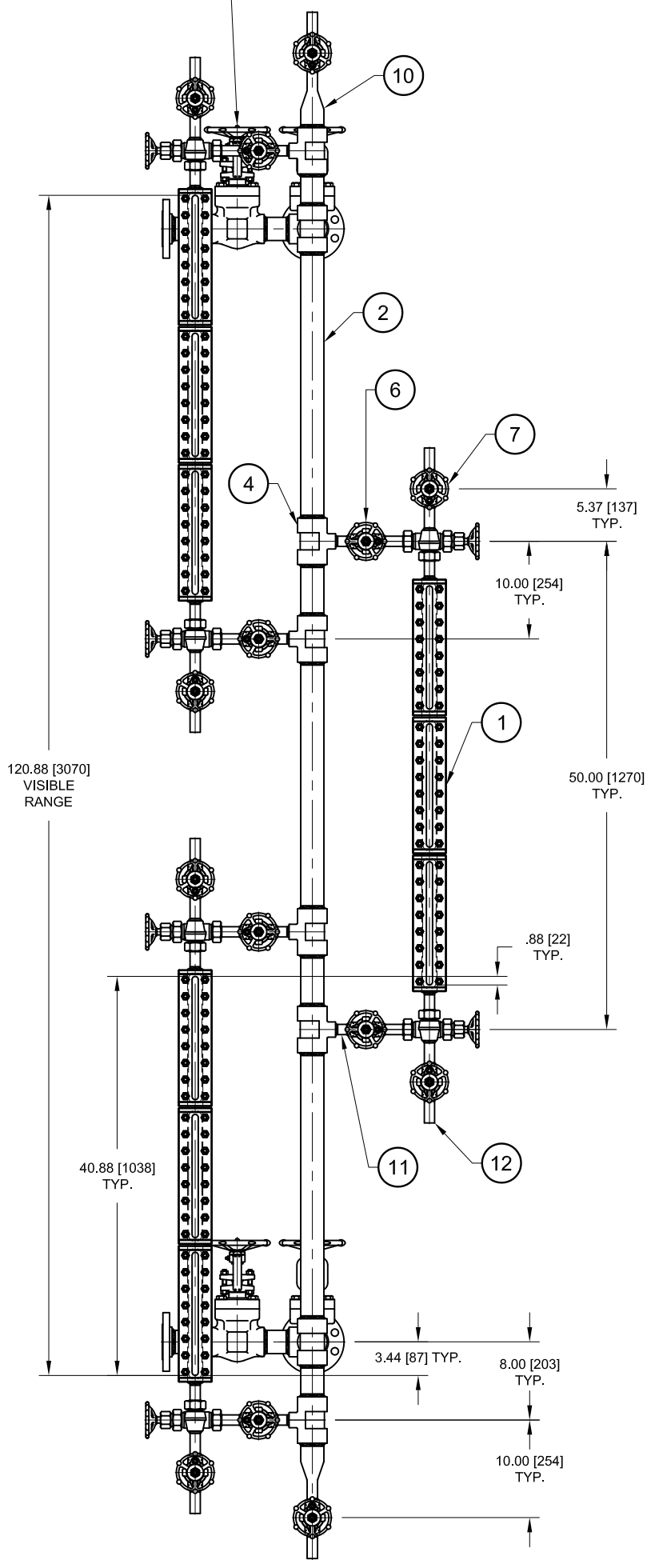

2	5/27/14	TITLE BLOCK WAS 94TM NOW 93TM	PCD	RET
1	4/14/14	ADD PURCHASER & PROJECT INFO	PCD	RET
REV	DATE	DESCRIPTION	DRN	APPD

UNLESS OTHERWISE NOTED ALL DIMENSIONS IN INCHES [mm]				
<b>QTS</b> Quest-Tec Solutions The New Standard of Level		13960 SOUTH WAYSIDE DR. HOUSTON, TEXAS 77048 OFFICE (281)240-0440 FAX (281)240-2440 WWW.QTSL.com		
TITLE 2" SCH 80 BRIDLE W/ (3) 93TM GAGE ASSEMBLIES & 2-U VALVE ASSEMBLIES, PROPOSED LAYOUT				
PER JOB# 022430				
DRN	PCD	DATE 4/8/14	SIZE B	DRAWING # 1-9-25876-1
CHKD	JLR	DATE 4/10/14	SCALE N.T.S.	REV 2
APPD	JLR	DATE 4/10/14	SHEET 1 OF 1	

**APPROVAL DRAWING:**

APPROVED AS IS TO MFG.

APPROVED AS NOTED TO MFG.

NOT APPROVED-RESUBMIT BEFORE MFG.

SIGNED BY: \_\_\_\_\_ DATE: \_\_\_\_\_

DRAWING TO BE RETURNED TO QTS BY: \_\_\_\_\_ TO AVOID DELAY.

THIS DRAWING IN DESIGN AND DETAIL IS OUR PROPERTY AND MUST NOT BE USED EXCEPT IN CONNECTION WITH OUR WORK. IT SHALL NOT BE REPRODUCED AND SHALL BE RETURNED TO US ON DEMAND. ALL RIGHTS ARE RESERVED.

SIMETRIC THRD ANGLE PROJECTION