

### CROSS SECTION

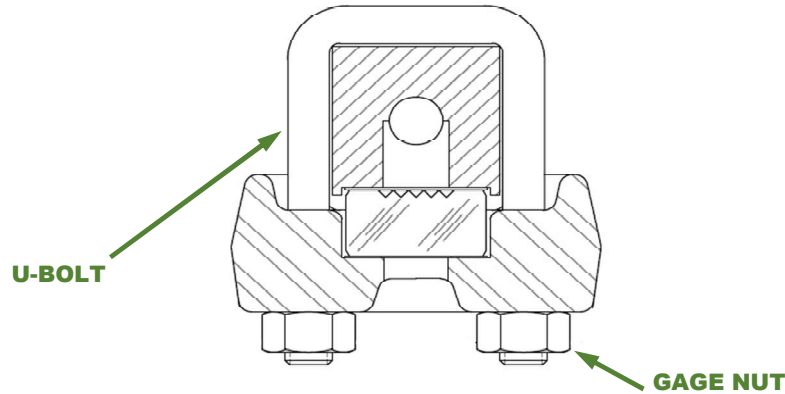

BOLTING		
MATERIAL GROUP	PART	
STANDARD	A-193 B7 U-BOLT	
	A-194 2H NUT	
M-GRADE	A-193 B7M U-BOLT	
	A-194 2HM NUT	
316 SS	A-193 B8M CL.2 U-BOLT	
	A-194 8M NUT	

STANDARD U-BOLT DIMENSIONS	
OVERALL LENGTH	3-3/4" (3.75")
DIAMETER	7-1/16" (0.4375")
CENTER TO CENTER	2" (2.00")

OPTIONAL SPRING WASHERS <sup>1</sup>	
PRESSURE SERIES	
L - LOW	
M - MEDIUM	
H - HIGH	

<sup>1</sup> Standard arrangement is 1 washers under each nut

PART QUANTITY PER GAGE SECTION (REFLEX)		
GAGE SIZE (NOMINAL GLASS SIZE)	NO. OF U-BOLTS PER SECTION	NO. OF NUTS PER SECTION
1	3	6
2	3	6
3	4	8
4	5	10
5	5	10
6	6	12
7	7	14
8	8	16
9	8	16

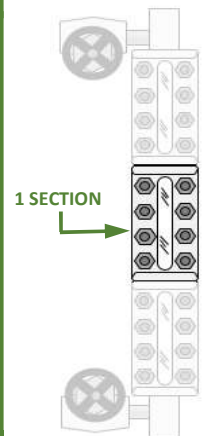

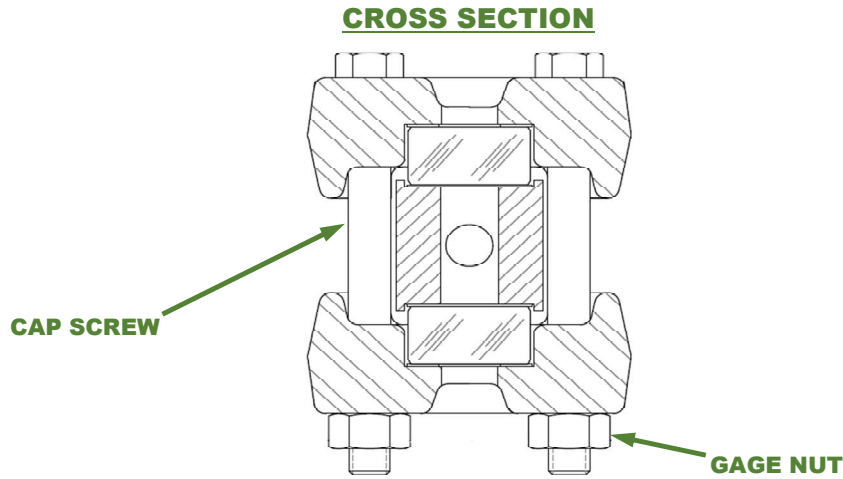

BOLTING		
MATERIAL GROUP	PART	
STANDARD	A-193 B7 CAP SCREW	
	A-194 2H NUT	
M-GRADE	A-193 B7M CAP SCREW	
	A-194 2HM NUT	
316 SS	A-193 B8M CL.2 CAP SCREW	
	A-194 8M NUT	

STANDARD CAP SCREW DIMENSIONS	
LENGTH (WITHOUT HEAD)	5-1/32" ( 5.03" )
DIAMETER	7-1/16" ( 0.4375" )

OPTIONAL SPRING WASHERS <sup>1</sup>	
PRESSURE SERIES	
L - LOW	
M - MEDIUM	
H - HIGH	

<sup>1</sup> Standard arrangement is 1 washer under each nut

PART QUANTITY PER GAGE SECTION (REFLEX)		
GAGE SIZE (NOMINAL GLASS SIZE)	NO. OF CAP SCREWS PER SECTION	NO. OF NUTS PER SECTION
1	6	6
2	6	6
3	8	8
4	10	10
5	10	10
6	12	12
7	14	14
8	16	16
9	16	16

